

DUAL AUDIO CONTROLLER MODEL TAC-200A

Installation and Operating Instructions

**Til Document No.
96REI97
Rev. D**

June 1997

 Technisonic Industries Limited

250 Watline Avenue, Mississauga, Ontario L4Z 1 P4 Tel:(905)890-2113 Fax:(905)890-5338
656 North French Road, Suite 2, Amherst, New York 14228 Tel:(716)691-0669

CAUTION

This unit contains static sensitive devices. Wear a grounded wrist strap and/or conductive gloves when handling printed circuit boards.

WARRANTY INFORMATION

The Model TAC-200A Audio Controller is under warranty for one year from date of purchase. Failed units caused by defective parts, or workmanship should be returned to:

Technisonic Industries Limited
250 Watline Avenue
Mississauga, Ontario L4Z 1 P4

Tel: (905) 890-21 13
Fax: (905) 890-5338

Technisonic Industries Limited
656 North French Road, Suite 2
Amherst, New York 14228

Tel: (716) 691-0669

REVISIONS for DOCUMENT?? **96RE197**

REV	PAGE	DESCRIPTION	DATE	APPROVED
C	2-3	FIGURE 2-2 Corrected pin ID's. on 15 pin "D".	17/03/97	
	2-6	FIGURE 2-5 Moved signal flow direction arrows from pins 9 to 1 and 11 to 3.	17/04/97	
D	2-3	FIGURE 2-2 changed pinout diagram to reflect corrected pinout sticker. TAPE L and TAPE R were reversed	11/06/97	

TABLE OF CONTENTS

Paragraph	Title	Page
SECTION 1	GENERAL DESCRIPTION	
1.1	Introduction	1-1
1.2	Description	1-1
1.3	Purpose of Equipment	1-1
1.4	Model Variations	1-1
1.5	Technical Summary	1-3
1.6	Operational Limitations	1-3
SECTION 2	PREPARATION FOR USE AND STORAGE	
2.1	General	2-1
2.2	Equipment Packaging Log	2-1
2.3	Wiring Requirements	2-1
2.4	Audio Panel installation	2-1
2.5	Kit Contents	2-2
2.6	Pin Connections and Locations	2-2
2.7	Headphones	2-2
2.8	Microphones	2-2
2.9	PTT	2-3
2.10	Main Power	2-3
2.11	DIR Audio In	2-3
2.12	ICS Tie and ICS Keying	2-9
2.13	Backlighting	2-9
2.14	Ground	2-9
2.15	Storage	2-1 0

LIST OF TABLES

Table No.	Title	
I-1	Operational Limitations	I-3
I-2	General Specifications	I-4
2-1	50 pin CANNON "D" Pin Connections	2-7
2-2	37 pin CANNON "D" Pin Connections	2-8
2-3	15 pin CANNON "D" Pin Connections	2-8

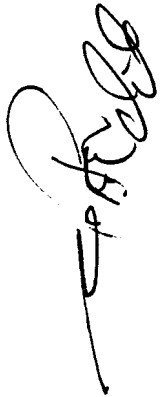
LIST OF ILLUSTRATIONS

Figure No.	Title	
I-1	TAC-200A Dual Audio Controller - General View	I-2
2-1	Outline Drawing	2-2
2-2	Pinout Diagram for 50 pin and 37 pin CANNON "D" Connectors	2-3
2-3	Connection Diagram for 50 pin "D" Connector	2-4
2-4	Connection Diagram for 37 pin "D" Connector	2-5
2-5	Connection Diagram for 15 pin "D" Connector	2-6
2-6	GROUND Isolation Jumper Locations	2-10
3-1	TAC-200A Front Panel Operators Switches and Controls	3-1
3-2	TAC-200A Configuration Controls	3-4

SECTION 1

GENERAL DESCRIPTION

1.1 INTRODUCTION

This publication provides operating and installation information on the Model TAC-200A, Dual Audio Controller manufactured by Technisonic Industries Limited. This unit is designed to provide high performance operation for installations requiring two completely independent audio controllers in a single panel mounted box. The pinout configuration of the rear interconnects, is optimized for superior operation specifications, and is plug and pin compatible with the ACCESS/A family of products.

1.2 DESCRIPTION

This high power audio controller delivers 500 mW of audio per side into 600 ohms at less than 2% distortion. Separate pilot and co-pilot transmit selector switches allows either operator to select any of the five aircraft communications transceivers or PA amplifier, while an audio input selector switch for each input allows selection of any combination of, or all, of the eight available aircraft audio inputs.

The TAC-200A has front panel selectable and adjustable VOX, LIVE or KEYED intercom (ICS). An EMERGENCY mode switch provides "straight through" transmit and receive audio for the pilot on the selected communications channel. The ISOLATE switch allows the pilot to isolate himself from the co-pilot (and the ICS system), so that he and the co-pilot may access different communications at the same time. In the NORMAL position, the pilot's audio is provided as selected by the co-pilot and is part of the ICS system. Separate RX and ICS volume controls are provided on each side of the panel along with a single ICS VOX threshold control. The TAC-200A will also provide ICS support for up to seven headsets.

1.3 PURPOSE OF THE EQUIPMENT

The TAC-200A Dual Audio Controller is designed to provide centralized audio management and control within an airborne communications environment. The unit has been packaged to minimize size and weight characteristics and is ideally suited for helicopter installations. The TAC-200A meets all of the requirements of US Forest Service "contractor furnished avionics" and can be used in conjunction with a TiL FM airborne transceiver to comply with all US Forest Service Contract Requirements. The product is also compliant with DO-160C categories relating to frequency response, cross-talk, vibration, humidity, temperature and altitude in an airborne environment.

1.4 MODEL VARIATION

The TAC-200A comes in two possible configurations. A +28VDC panel lighting version and a +5VDC panel lighting version. Operationally the two are identical. The default is +28VDC backlighting. The backlighting is achieved through solid state devices, and produces virtually no heat and a light wavelength of approximately 580nm. The front panel background colour itself, is a choice of either matte black or Cessna cadet grey. Default is black. See TAC-200A price list for model variations.

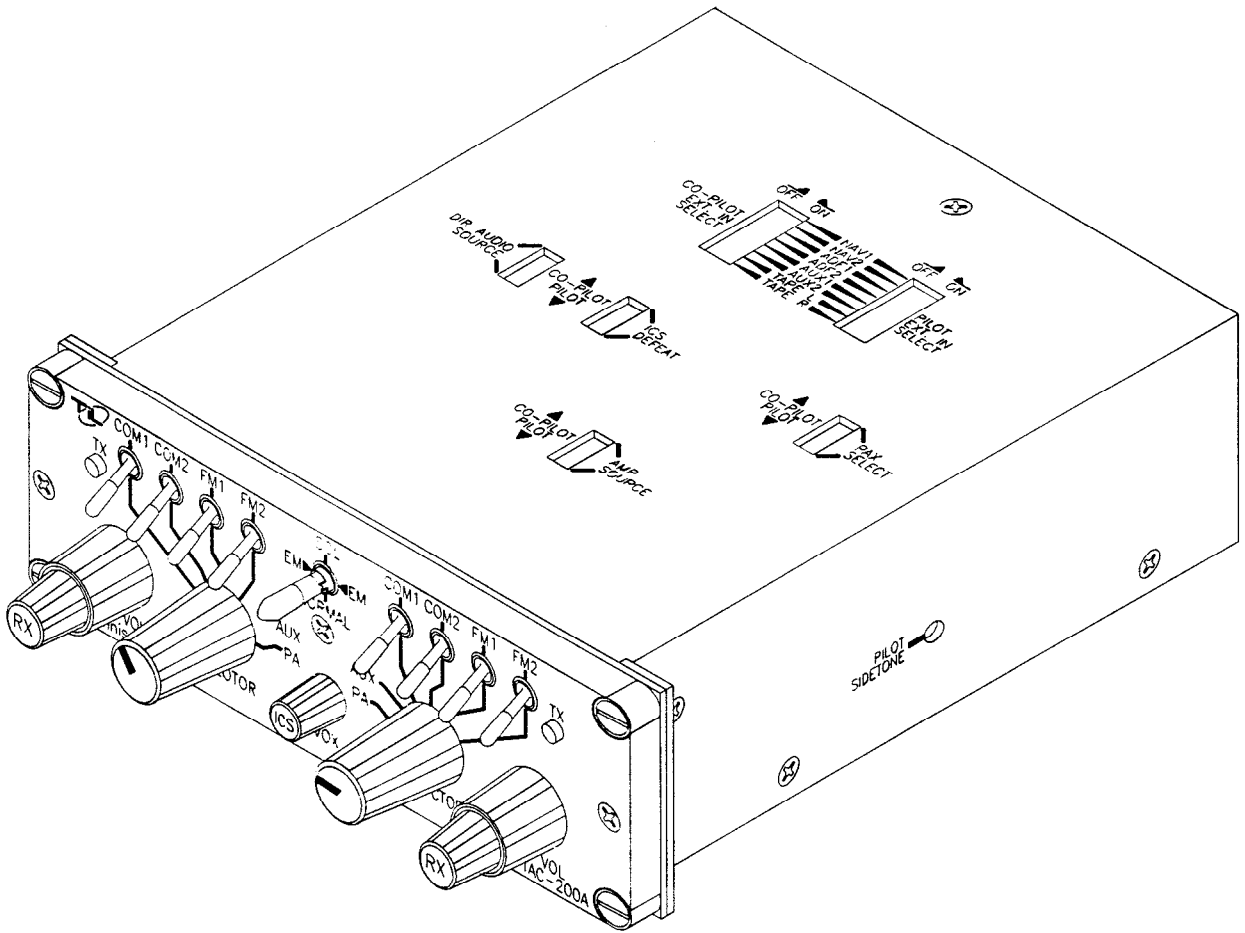

FIGURE I-1 TAC-200A DUAL AUDIO CONTROLLER - GENERAL VIEW

1.5 TECHNICAL SUMMARY

A summary of the relevant electrical, operational, mechanical and physical characteristics of the control panel are given in **Table 1-2**, General Specifications.

1.6 OPERATIONAL LIMITATIONS

These specifications are the minimum and maximum operating characteristics, within which the TAC-200A should operate reliably. **Table I-1** shows the operational limitations of the TAC-200A.

TABLE I-1 OPERATIONAL LIMITATIONS	
I POWER IN	Min. +30Vdc (continuous) Max. + 35Vdc
F USE	3A
T EMP	Min. -40°C Max. +71°C
H UMIDITY	Max. 95% Non Condensing
MIC Signal level	Max. -6dBm
Impedance	Min. 100Ω Max. 1KΩ
COMM 81 ICS TIE SIGNALS:	
Transceiver Signal level	Max. + 15dBm
Impedance	Min. 100Ω Max. 1KΩ
Receiver Signal level	Max. + 15dBm
Impedance	Min. 100Ω Max. 1KΩ
ICS Bus Signal level	Max. + 15dBm
Impedance	Min. 100Ω Max. 1KΩ
H EADSET OUTPUT LOADING	Min. 1 OOR Max. 1KΩ

TABLE 1-2 GENERAL SPECIFICATIONS

MODEL TAC-200A
Dual Audio Controller

PHYSICAL CHARACTERISTICS:

Width	5.76 inches
Height	1.90 inches
Depth	6.00 inches
Weight (max.)	2.0 lbs. (909 g)
Mounting	Standard Dzus, 4 fasteners

POWER SOURCE REQUIREMENTS:

DC Voltage (Negative Ground)	28 Vdc (-20% + 15%)
DC Current	350 mA (nominal)
Backlighting Input:	
Standard	28 Vdc @ 150 mA
Optional	5 Vac @ 700 mA

TECHNICAL CHARACTERISTICS:

Input Impedance	1000 Ohms (minimum)
Headset Output Impedance	56 Ohms
Audio Power Output	500 milliwatts (per side) into 600 Ohms
Audio distortion	less than 2% THD at rated output
Audio Frequency Response	within 3 dB from 300 Hz to 6000 Hz
Hum and Noise Level	better than 50 dB
Input Muting (when mic is keyed)	better than 55 dB
Deselected input isolation	better than 60 dB between inputs

ENVIRONMENTAL:

Temperature	-40°C to +70° Celsius
Humidity	95% Non-condensing
Shock	12 g (any axis)
Altitude	15,000 feet

SECTION 2

INSTALLATION INSTRUCTIONS

2.1 GENERAL

This section contains information and instructions for the correct installation of the TAC-200A, Dual Audio Controller.

Make certain that the unit is correctly operating in accordance with the equipment user's requirements prior to releasing the equipment for service.

2.2 EQUIPMENT PACKING LOG

Unpack the equipment and check for any damage that may have occurred during transit. Save the original shipping container for returns due to damage or warranty claims. Check that each item on the packing slip has been shipped in the container. Verify that the equipment's backlighting configuration is the same as that required.

2.3 WIRING REQUIREMENTS

Airframe wiring should be MS22759 Tefzel or Raychem 44 (81044) single conductor and shielded wire. Heatshrink solder sleeves (such as Raychem or equivalent) should be utilized for shield termination.

All Microphone audio input line connections should be made with Shielded Cables. Audio output lines may be twisted pairs. The power cables should be a minimum of #22 AWG. Keying lines may be #24 AWG

DO NOT bundle low level audio lines with RF coaxial cables, motor, pump or blower wiring which can cause coupling between the various systems, especially during RF transmission or pump/blower mechanical operation. Maintain as much distance as possible from these types of wire bundles.

2.4 AUDIO PANEL INSTALLATION

The TAC-200A Audio Panel is designed to be Dzus mounted and should be installed in conjunction with installation kit P/No. **969732**. See **Figure 2-1** for an outline drawing of the unit with dimensions to facilitate the installation.

All configurable and variable options of the TAC-200A can be set or changed simply and without requiring the opening of the unit.

- A block diagram of the **50 pin "D"** connections is provided in **Table 2-1**
- A block diagram of the **37 pin "D"** connections is provided in **Table 2-2**
- A block diagram of the **15 pin "D"** connections is provided in **Table 2-3**

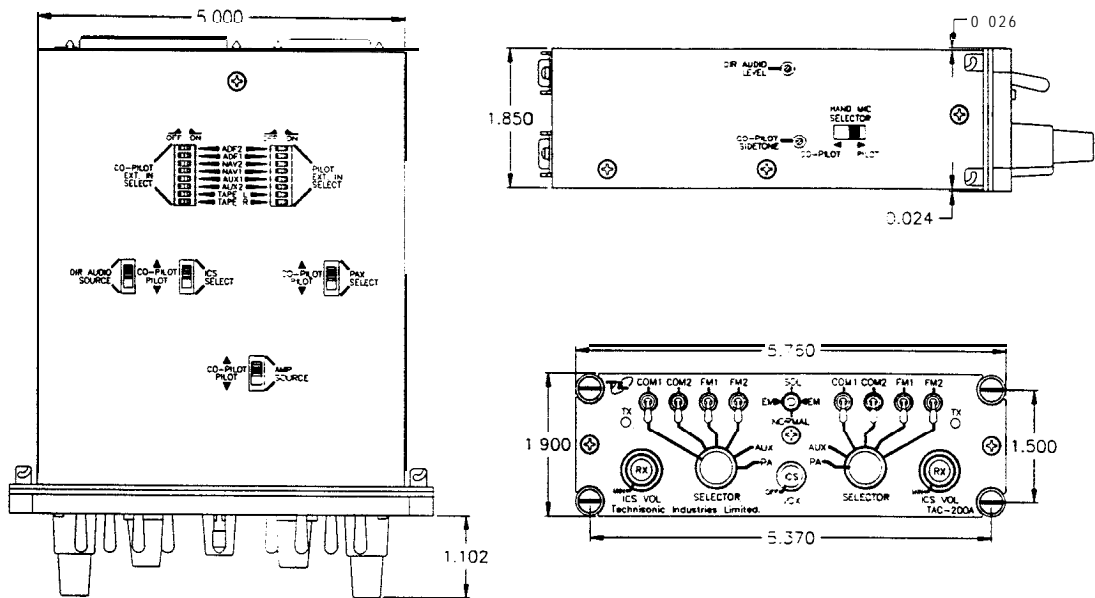

FIGURE 2-1 Outline Drawing for Model TAC-200A Audio Controller

2.5 INSTALLATION - KIT CONTENTS

The installation kit P/No. 969732, consists of:

1. One 50 pin Cannon D mating connector (female) complete with crimp pins and hood.
2. One 37 pin Cannon D mating connector (female) complete with crimp pins and hood.
3. One 15 pin Cannon D mating connector (male) complete with crimp pins and hood.

2.6 INSTALLATION - PIN LOCATIONS AND CONNECTIONS

The pin numbers and locations for the 50, 37 and 15 pin Cannon D connectors, located on the rear of the TAC-200A Audio Controller, are depicted in **Figure 2-2**. Pin connections descriptions are provided in **Tables 2-1 (50 pin "D")**, **2-2 (37 pin "D")**, and **2-3 (15 pin "D")**.

2.7 HEADPHONE INSTALLATION

The TAC-200A is intended for use with industry standard 600 ohm headphones there is no provision for connection to an 8 ohm or 4 ohm speaker. All Headphone connections for Pilot, Co-pilot, and Passengers are listed in **Table 2-3 (15 pin "D")**. See also the connection diagram **Figure 2-5**.

2.8 MICROPHONE INSTALLATION

All microphone connections to the TAC-200A must be done with shielded cables. The inputs are intended for use with standard Carbon or equivalent Microphones. Microphone connections are listed in **Table 2-1 (50 pin "D")**. See also the connection diagram **Figure 2-3**.

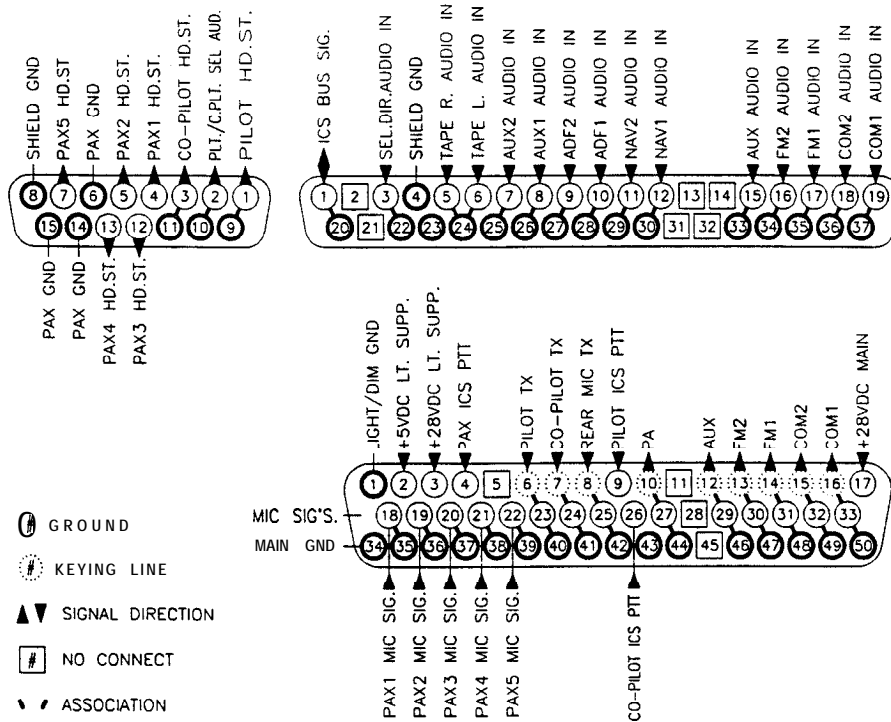

FIGURE 2-2 Pinout Diagram for 50 pin, 37 pin, and 15 pin "D" connectors

2.9 PTT CONNECTIONS

The Pilot, Co-pilot and rear microphones require a PTT (Push To Talk) button or switch to key the transceivers as required. If a Hand-held microphone is used, tie the PTT button to the appropriate key line. If the Microphone is incorporated into the Headset. An external Switch ie/ the cyclic switch, will be required to Key the transmitter. Any audio received by the Pilot, Co-pilot or Rear microphones without the PTT keyed, will pass through the intercom.

The Pilot, Co-pilot, and Transceivers are keyed by applying Ground to any one of the appropriate key lines listed in Table 2-1 (50 pin "D").

See also connection diagram Figure 2-3.

2.10 MAIN POWER + 28VDC

The main power + 28VDC (± 20%) is connected to pin 17 of the 50 pin (lower) "D"connector. As previously indicated, this connection should be made with #22 AWG wire. See Table 2-1 (50 pin "D"). See also connection diagram Figure 2-3.

2.11 DIR AUDIO IN

The DIR audio input is an input source which is connected directly to the headset amplifiers, and is not affected by any of the front panel control settings. This input is typically used for audible warning system tones or other signals which must be audible at all times. The output level is adjustable only by the potentiometer on the left side of the unit. See Figure 3-2.

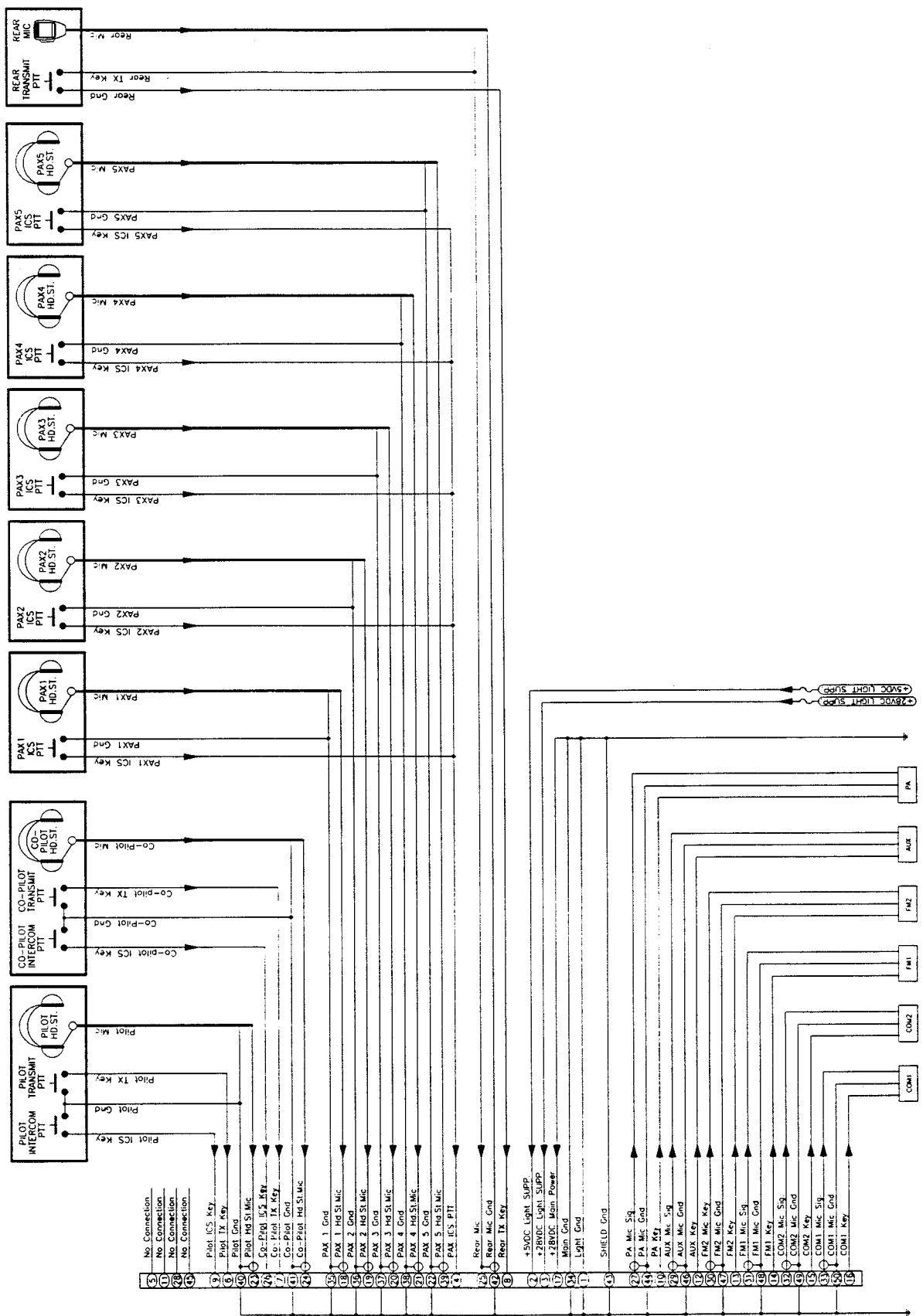

Figure 2-3 Connection Diagram for 50 pin "D" connector.

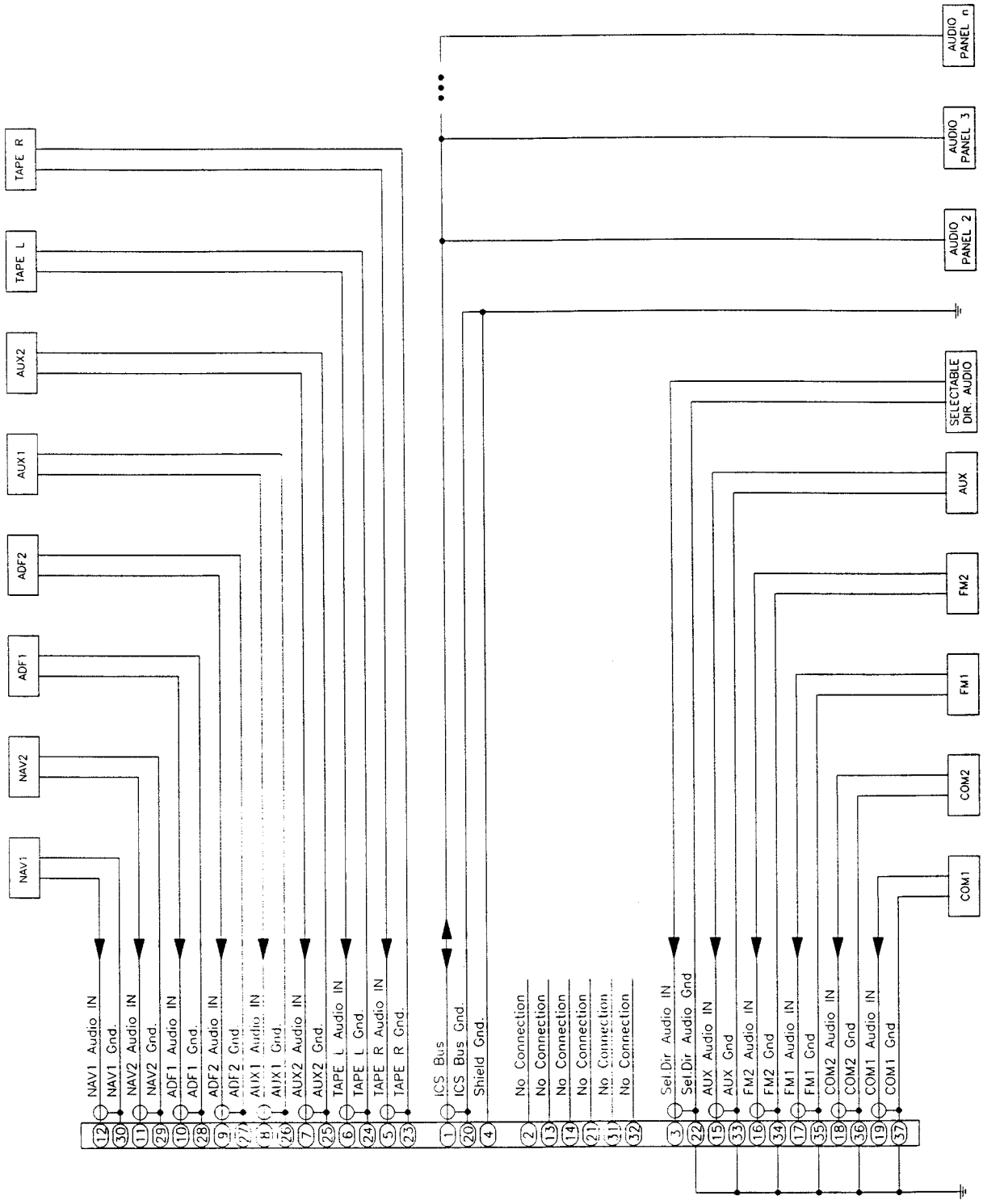

Figure 2-4 Connection Diagram for 37 pin "D" connector.

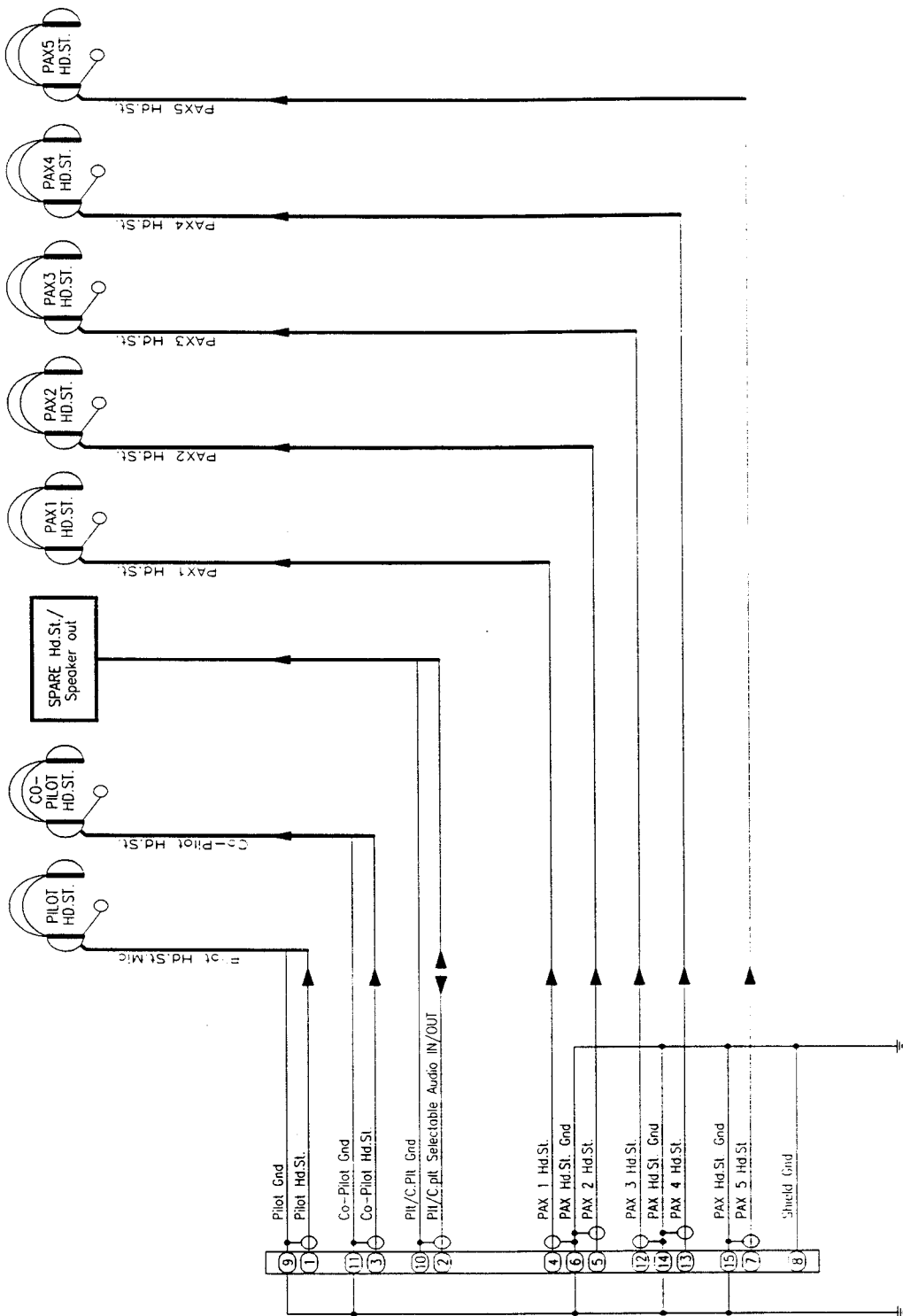

Figure 2-5 Connection Diagram for 15 pin "D" connector.

**TAC-200A AUDIO PANEL
JI, 50-PIN D Connections**

Pin #	Description	Pin #	Description
1	Light/Dim - GND	26	Co-Pilot - ICS Keying
2	+5VDC - Light Supp.	27	PA - Mic out
3	+28VDC - Light Supp.	28	N/C
4	PAX - ICS Keying	29	AUX - Mic out
5	N/C	30	FM2 - Mic out
6	Pilot - TX Keying	31	FM1 - Mic out
7	Pilot - TX Keying	32	COM2 - Mic out
8	Rear Mic - TX Keying	33	COM1 - Mic out
9	Pilot - ICS Keying	34	MAIN GND
10	PA - Keying	35	PAX1 - GND
11	N/C	36	PAX2 - GND
12	AUX - Keying	37	PAX3 - GND
13	FM2 - Keying	38	PAX4 - GND
14	FM1 - Keying	39	PAX5 - GND
15	COM2 - Keying	40	Pilot Mic - GND
16	COM1 - Keying	41	Co-Pilot Mic - GND
17	+28VDC - Supply	42	Rear Mic - GND
18	PAX1 - Mic in	43	Shield - GND
19	PAX2 - Mic in	44	PA Mic - GND
20	PAX3 - Mic in	45	N/C
21	PAX4 - Mic in	46	AUX Mic - GND
22	PAX5 - Mic in	47	FM2 Mic - GND
23	Pilot - Mic in	48	FM1 Mic - GND
24	Co-Pilot - Mic in	49	COM2 Mic- GND
25	Rear Mic - Mic in	50	COM1 - GND

TABLE 2-1

**TAC-200A AUDIO PANEL
J7, 37-Pin D Connections**

Pin #	Description	Pin #	Description
1	ICS BUS - Bi-Dir.	20	ICS Bus - GND
2	N/C	21	N/C
3	Selectable Direct - Audio In	22	Selectable Direct Audio - GND
4	Shield GND	23	TAPE Rt - GND
5	TAPE Rt - Audio In	24	TAPE Lft - GND
6	TAPE Lft - Audio In	25	AUX2 - GND
7	AUX2 - Audio In	26	AUX1 - GND
8	AUX1 - Audio In	27	ADF2 - GND
9	ADF2 - Audio In	28	ADF1 - GND
10	ADF1 - Audio In	29	NAV2 - GND
11	NAV2 - Audio In	30	NAV1 - GND
12	NAV1 - Audio In	31	N/C
13	N/C	32	N/C
14	N/C	33	AUX - GND
15	AUX - Audio In	34	FM2 - GND
16	FM2 - Audio In	35	FM1 - GND
17	FM1 - Audio In	36	COM2 - GND
18	COM2 - Audio In	37	COM1 - GND
19	COM1 - Audio In		

TABLE 2-2

**TAC-200A AUDIO PANEL
J9, 15 Pin D Connections**

Pin #	Description	Pin #	Description
1	Pilot - Headset	9	Pilot Headset - GND
2	Pilot/Co-Pilot - Selectable Audio Out / Alert Audio In	10	Pilot/Co-Pilot Selectable Audio / Alert Audio In - GND
3	Co-Pilot - Headset	11	Co-Pilot Headset - GND
4	PAX1 - Headset	12	PAX3 - Headset
5	PAX2 - Headset	13	PAX4 - Headset
6	PAX Headset - GND	14	PAX Headset - GND
7	PAX5 - Headset	15	PAX Headset - GND
8	Shield - GND		

TABLE 2-3

2.12 ICS TIE AND ICS KEYING

The ICS Bus is a bidirectional audio line allowing connection of multiple intercom systems and panels in one installation. This can be achieved simply by connecting together all of the ICS Bus signals of all the devices.

PLEASE NOTE:

In installations where separate ICS keying for the passengers is not possible, the PAX ICS Keying line must be connected to ground for the intercom to work with the VOX knob in the keyed (fully counter-clockwise) position.

See Table 2-1 (50 pin "D"). See also connection diagram Figure 2-3.

2.13 BACKLIGHTING POWER + 28VDC / + 5VDC

The backlighting power for the front panel of the TAC-200A is supplied via pin 3 of the 50pin connector for +28VDC, and pin 2 of the 50 pin connector for +5VDC. Do NOT supply more than + 5VDC (-15% + 15%). Unless ordered and indicated otherwise on the rear of the TAC-200A, the unit is shipped with the +28VDC backlighting option.

See Table 2-1 (50 pin "D"). See also connection diagram Figure 2-3.

2.14 GROUND

The TAC-200A Audio Controller is designed for optional Ground Isolation from the Airframe. This is necessary in some cases where the Airframe Ground might cause noise in the Audio system. The TAC-200A is factory configured for Isolation. Despite the nomenclature, all ground lines are common. If ground isolation is not required or desired, the ground isolation jumpers may be connected. See Figure 2-5 for location of ground isolation jumpers.

Main ground to the Audio Controller is on pin #34 of the 50 pin "D" connector. All other grounds are common to this and are on pins #1, #35 - #44, #46 - #50 these GROUND connections are depicted as shaded cells in Table 2-1.

Ground connections on the 37 pin "D" connector are on pins #4, #20, #22 - #30, and #33 - #37. These GROUND connections are depicted as shaded cells in Table 2-2.

Ground connections on the 15 pin "D" connector are on pins #6, #9 - #11, and #14 - #15. These GROUND connections are depicted as shaded cells in Table 2-3.

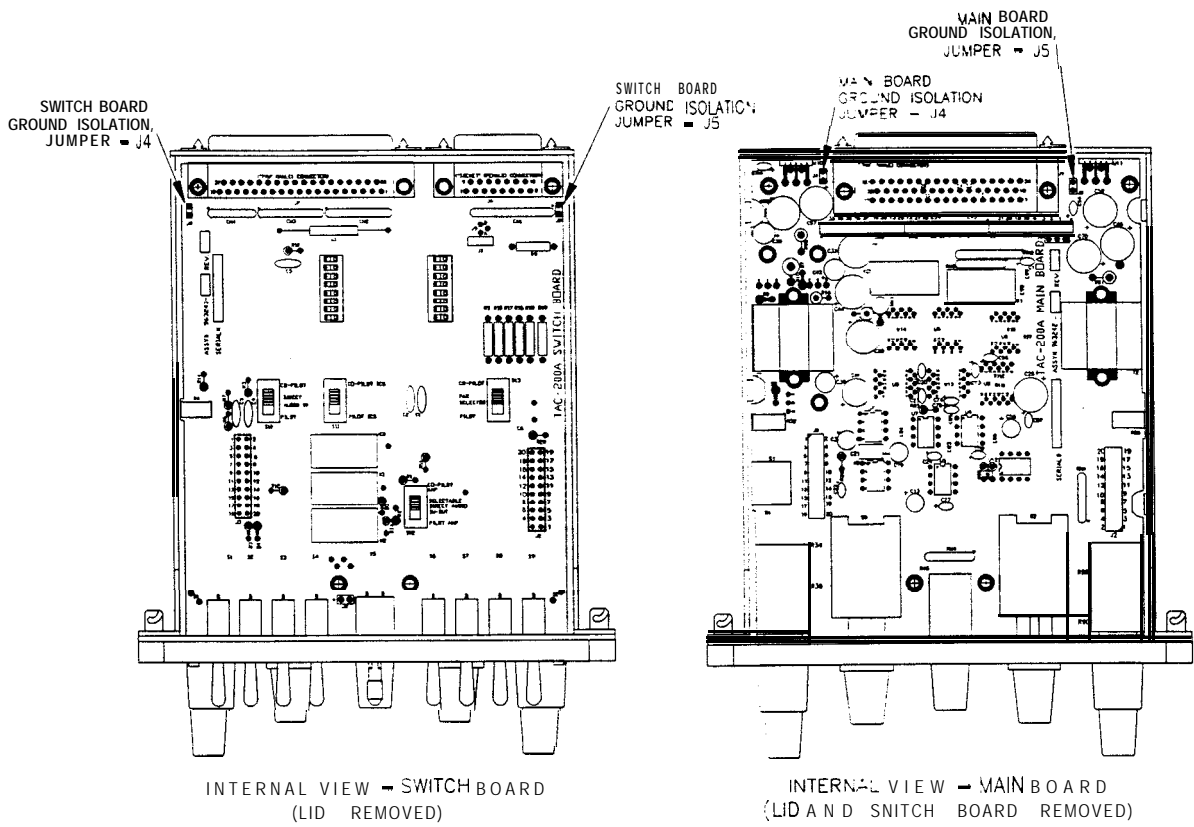

FIGURE 2-6 GROUND ISOLATION JUMPER LOCATIONS

2.15 STORAGE

When not in use, Store the TAC-200A in the original Anti-Static bag if possible and in a non Humid place. Storage temperatures should not exceed + 70°C or be less than -40°C.

SECTION 3

OPERATING INSTRUCTIONS

3.1 FRONT PANEL OPERATORS SWITCHES AND CONTROLS

This section deals with the explanation and description of all the controls of the TAC-200A Audio Controller. All Pilot and Co-pilot Controls are on the front Panel of the unit and are variable or selectable.

The TAC-200A Maintains the industry Standard configuration of Pilot on the Right and Co-pilot on the Left ergonomics. A complete definition of the controls are given in Figure 3-1.

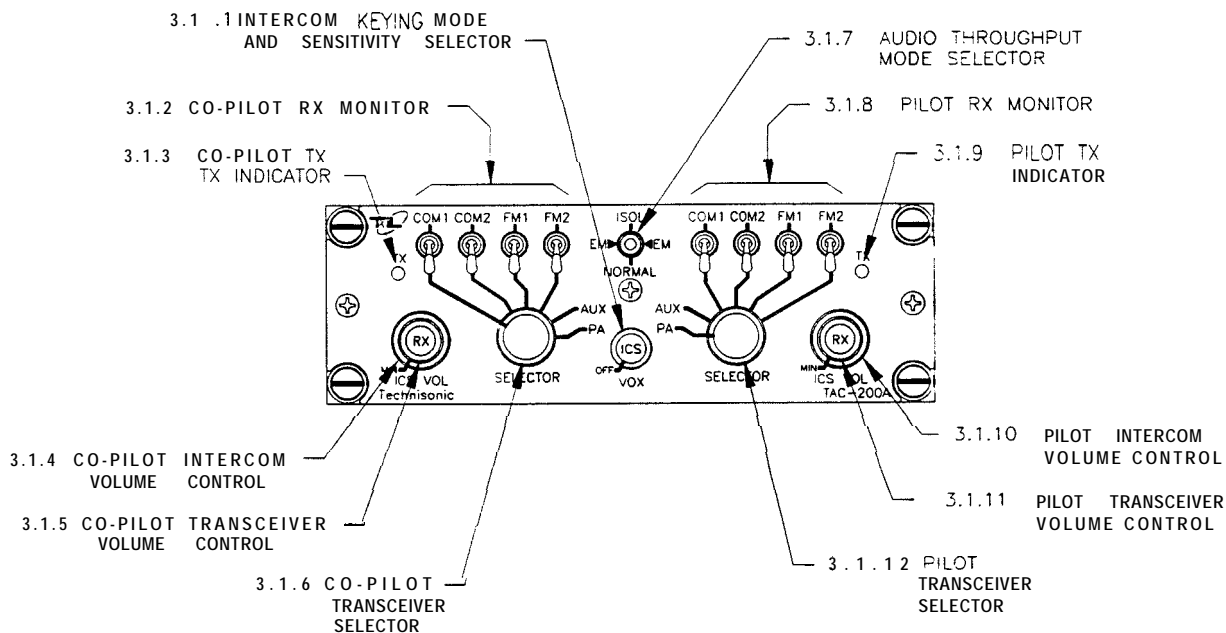

FIGURE 3-1 TAC-200A FRONT PANEL OPERATOR'S SWITCHES AND CONTROLS

3.1.1 INTERCOM KEYING MODE AND SENSITIVITY SELECTOR

This adjustment selects VOX mode ON or OFF. In the ON mode, the audio produced by any of the microphones will break the squelch of the intercom and will be routed through the intercom system. The threshold audio level required to break the squelch is also adjustable by this knob. A setting of fully clockwise on the knob will leave the intercom keyed at all times. When set to OFF (fully counterclockwise), the intercom will only receive audio when intercom PTT is keyed.

3.1.2 CO-PILOT RX MONITOR

These four switches indicated COM1, COM2, FM1 and FM2, allow the Co-pilot to monitor the Receivers - independant of the setting of the Transceiver SELECTOR (3.1.6). Any number or combination may be used at the same time.

3.1.3 CO-PILOT TX INDICATOR

This LED indicator indicates that the audio received from the Co-pilot Microphone and the transmit signal (PTT), after keying the PTT button, is being routed to the Transceiver selected via the Transceiver SELECTOR (3.1.6).

3.1.4 CO-PILOT INTERCOM VOLUME CONTROL

This knob controls the Co-pilot's intercom volume level. Fully clockwise being the maximum volume level and counter-clockwise the minimum. This control may have an affect on the Passenger headset volume, depending on the position of the Passenger Headset Amplifier Source switch (3.2.10 - Figure 3-2).

3.1.5 CO-PILOT RX (TRANSCIVER) VOLUME CONTROL

This knob controls the Co-pilot's Transceiver volume level. The Audio at this point is selected from any combination of the RX Monitor switches (3.1.2). and the Transceiver SELECTOR (3.1.6). Fully clockwise being the maximum volume level and counter-clockwise the minimum. This control may have an affect on the Passenger headset volume, depending on the position of the Passenger Headset Amplifier Source switch (3.2.10 - Figure 3-2).

3.1.6 CO-PILOT TRANSCEIVER SELECTOR

The setting of this switch determines which Transceiver will transmit the incoming Co-pilot's microphone audio and which Receiver the Co-pilot's headset will monitor, independant of the RX Monitor (3.1.2) switch settings. The setting also determines which transceiver will be keyed by the PTT switch of the Microphone.

3.1.7 AUDIO THROUGHPUT MODE SELECTOR

In the **Normal** position, the TAC-200A operates actively with amplification of input signals to all respective headsets.

In the Emergency mode, audio signals from any of the receivers will pass to the headsets without amplification. This mode of operation is used in the event that the power to the TAC-200A is interrupted.

**** Due to the nature of the PTT/Keying circuitry, + 28VDC is required at all times to allow the connected transceivers to transmit ****

In the ISOLate position, all of the intercom audio traffic is disconnected from the Pilot or Co-pilot as is determined by the setting of the ICS SELECT switch (3.2.2).

****Keep in mind that due to the fact that the Passenger Headsets (PAX1-5) share either the Pilot or Co-pilot amplifier as per the PAX SELECT switch setting (3.2.7), whichever Pilot or Co-pilot is disconnected from the Intercom, the connected Passengers will also be disconnected. ****

3.1.8 PILOT RX MONITOR

These four switches indicated COM1, COM2, FM1 and FM2 allow the Pilot to monitor the Receivers - independent of the setting of the Transceiver SELECTOR (3.1 .1 2). Any number or combination may be used at the same time.

3.1.9 PILOT TX INDICATOR

This LED indicator indicates that the audio received from the Pilot Microphone and the transmit signal (PTT), after keying the PTT button, is being routed to the Transceiver selected via the Transceiver SELECTOR (3.1.12).

3.1 .10 PILOT INTERCOM VOLUME CONTROL

This knob controls the Pilot's intercom volume level. Fully clockwise being the maximum volume level and counter-clockwise the minimum. This control may have an affect on the Passenger headset volume, depending on the position of the Passenger Headset Amplifier Source switch (3.2.10 - Figure 3-2).

3.1 .1 1 PILOT RX (TRANSCIVER) VOLUME CONTROL

This knob controls the Pilot's Transceiver volume level. The Audio at this point is selected from any combination of the RX Monitor switches (3.1.8), and the Transceiver SELECTOR (3.1 .1 2). Fully clockwise being the maximum volume level and counter-clockwise the minimum. This control may have an affect on the Passenger headset volume, depending on the position of the Passenger Headset Amplifier Source switch (3.2.10 - Figure 3-2).

3.1.12 PILOT TRANSCEIVER SELECTOR

The setting of this switch determines which Transceiver will transmit the incoming Pilot's microphone audio and which Receiver the Pilot's headset will monitor, independent of the RX Monitor (3.1.8) switch settings. The setting also determines which transceiver will be keyed by the PTT switch of the Microphone.

3.2 CONFIGURATION SWITCHES AND CONTROLS

The TAC-200A Audio Controller has been designed to be configurable upon installation without the need to open the unit. All controls and/or selections are made via the switches on the left, right and top side of the chassis lid.

A complete definition of the controls are given in Figure 3-2.

3.2.1 DIRECT AUDIO DESTINATION

The TAC-200A has a direct audio input which can be routed directly to either the Co-pilot or Pilot output amplifiers. The switch determines the recipient of the DIRECT audio in signal. The Passengers may also be recipients of the audio depending on the setting of the Passenger Headset Amplifier Source switch (3.2.10).

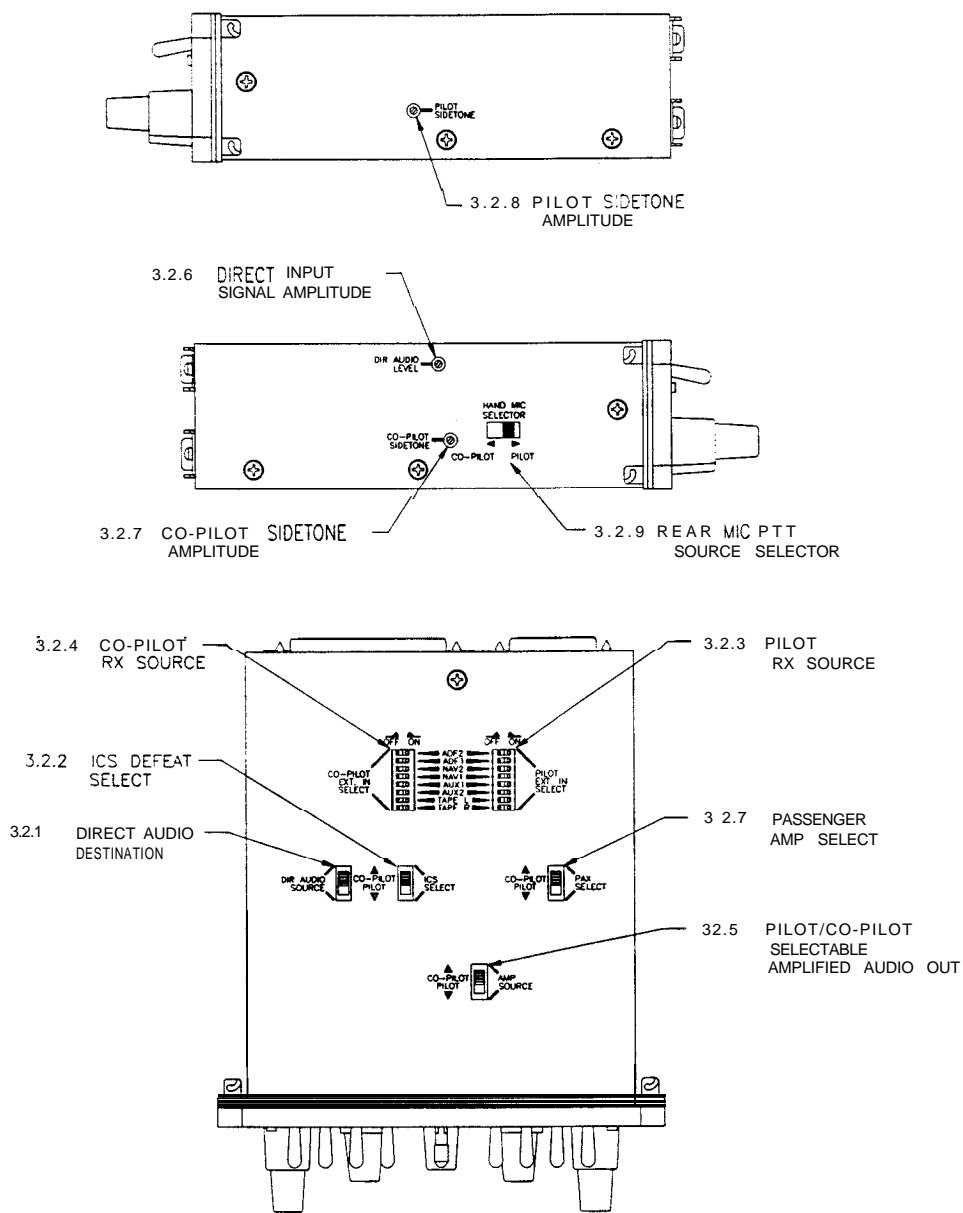

FIGURE 3-2 TAC-200A CONFIGURATION CONTROLS

3.2.2 ICS DEFEAT

During this switch determines which Microphone (Pilot or Co-pilot) may not communicate with the intercom.

3.2.3 PILOT RX SOURCE

These DIP-switches select all or any combination of the available Receiver audio sources connected to the TAC-200A and when selected, these input signals can be monitored with other transceivers selected by the Pilot Transceiver Selector (3.1.12). This audio is adjusted via the Pilot RX volume control (3.1 .1 1).

3.2.4 CO-PILOT RX SOURCE

These DIP-switches select all or any combination of the available Receiver audio sources connected to the TAC-200A and when selected, these input signals can be monitored with other transceivers selected by the Co-pilot Transceiver Selector (3.1.6). This audio is adjusted via the Co-pilot RX volume control (3.1.5).

3.2.5 PILOT/CO-PILOT SELECTABLE AMPLIFIED AUDIO OUT

This switch selects the amplifier source for pin #1 3 of the 37 pin "D". The audio on this line is selected from either the Pilot or Co-pilot amplifier output and the level is adjusted via the Pilot or Co-pilot RX (Transceiver) and Intercom volume controls.

3.2.6 DIRECT INPUT AMPLITUDE

This potentiometer limits the amplitude of the DIRect audio input signal in 3.2.1. The amplitude is increased by rotating the potentiometer screw clockwise and is decreased by rotating the screw counter-clockwise. Front panel controls have no affect on this input signal.

3.2.7 CO-PILOT SIDETONE LEVEL

This potentiometer adjusts the level at which the Co-pilot is able to hear himself while he has keyed the Transceiver to transmit. The amplitude is increased by rotating the potentiometer screw clockwise and is decreased by rotating the screw counter-clockwise. This is typically adjusted during installation.

3.2.8 PILOT SIDETONE LEVEL

This potentiometer adjusts the level at which the Pilot is able to hear himself while he has keyed the Transceiver to transmit. The amplitude is increased by rotating the potentiometer screw clockwise and is decreased by rotating the screw counter-clockwise. This is typically adjusted during installation.

3.2.9 REAR MIC PTT SELECTOR

This determines whether the REAR microphone will inject audio and PTT keying signal into the Pilot or Co-pilot selected Transceiver. This is the only other MIC aside from the Pilot and Co-pilot, whose audio can be supplied to the selected Transceiver.

3.2.10 PASSENGER HEADSET AMPLIFIER SELECTOR

This Switch selects the source amplifier for the Passenger Headsets. The Source amplifier is either the Pilot amplifier or Co-pilot amplifier. Whichever selected, the ICS and RX (Transceiver) volume control knobs will have an affect on the Passenger Headsets. The Passenger Headsets will produce the same audio as the Pilot or Co-pilot as set by this switch.