

**VHF/UHF FM
AIRBORNE TRANSCEIVER
REMOTE CONTROL HEAD
MODEL RC-500**

(P/N 991097-I , -2)

**Installation and
Operating Instructions**

**Til Document No.
99RE260
Rev. N/C
issue n/c**

November 1999

Technisonic Industries Limited

250 Watline Avenue, Mississauga, Ontario L4Z 1 P4 Tel:(905)890-2113 Fax:(905)890-5338
3840 East Robinson Road, Suite 214, Amherst, New York 14228 Tel:(716)691-0669

CAUTION

This unit contains static sensitive devices. Wear a grounded wrist strap and/or conductive gloves when handling printed circuit boards.

Warning:

Changes or modifications not expressly approved by Technisonic industries could void the user's authority to operate the equipment.

WARRANTY INFORMATION

The Model RC-500, Remote Control Head is under warranty for one year from date of purchase. Failed units caused by defective parts, or workmanship should be returned to:

Technisonic Industries Limited

250 Watline Avenue
Mississauga,
Ontario L4Z 1P4

Tel: (905) 890-2113 Fax: (905) 890-5338

Technisonic Industries Limited

3840 E. Robinson Road, Suite 214
Amherst,
New York 14228

Tel: (716) 691-0669

Summary of DO-1 60C Environmental Testing for Technisonic Model RC-500, Remote Control Head for the Model TFM-500 Transceiver..

Conditions	Section	Description of Conducted Tests
Temperature and Altitude	4.0	Equipment tested to categories B2 and D1.
Vibration	8.0	Equipment is tested without shock mounts to categories B, M and N.
Magnetic Effect	15.0	Equipment is class Z.
Power Input	16.0	Equipment tested to category B.
Voltage Spike	17.0	Equipment tested to category B.
RF Emission	21.0	Equipment tested to category Z.

TABLE OF CONTENTS

Paragraph	Title	Page
SECTION 1 GENERAL DESCRIPTION		
1.1	Introduction	1-1
1.2	Description	1-1
1.3	Purpose of Equipment	1-1
1.4	Model Variation	1-2
1.5	Technical Summary	1-2

SECTION 2 OPERATING INSTRUCTIONS

2.1	Operating Instructions	2-2
-----	------------------------------	-----

SECTION 3 INSTALLATION INSTRUCTIONS

3.1	General	3-1
3.2	Equipment Packing Log	3-1
3.3	Transceiver Installation	3-1
3.4	Installation Kit - Contents	3-1
3.5	Antenna Installation	3-1
3.6	Installation - Pin Locations and Connections	3-1
3.7	Wiring Instructions	3-3

LIST OF TABLES

Table No.	Title	Page
3-1	9-pin D Connections	3-3

LIST OF ILLUSTRATIONS

Figure No.	Title	Page
2-1	Operator's Switches and Controls	2-1
3-1	Outline Drawing	3-2
3-2	Wiring Connections	3-4

SECTION 1

GENERAL DESCRIPTION

1.1 INTRODUCTION

This publication provides operating and installation information on the RC-500 Remote control head manufactured by Technisonic Industries Limited. The unit offers a secondary control or slaved control position for the Technisonic TFM-500 VHF/UHF FM Transceiver.

1.2 DESCRIPTION

The RC-500 is a microprocessor controlled display and keypad capable of RS232 serial communications with the TFM-500. The front panel is similar to the TFM-500 and displays the same information.

1.3 PURPOSE OF EQUIPMENT

The RC-500 remote control head provides a secondary slaved control point for the TFM-500 where the TFM-500 is not accessible or visible to the second user.

1.4 MODEL VARIATION

There are four variations of the Model RC-500 Transceiver. All units offer identical features and performance except for the following differences:

K-500, P/N 99RE260-1	GREEN display and 28 Volt back lighting.
RC-500, P/N 99RE260-1 (5V),	GREEN display and 5 Volt back lighting.
RC-500, P/N 99RE260-2	RED display and 28 Volt back lighting.
RC-500, P/N 99RE260-2 (5V),	RED display and 5 Volt back lighting.

Both P/N's 99RE260-1 and 99RE260-2 are always provided with 28 Volt back lighting unless a specific request is made for 5 Volt AC operation.

1.5 TECHNICAL CHARACTERISTICS

<u>Specification</u>	<u>Characteristic</u>
<u>GENERAL</u>	
Model Designation:	RC-500
Physical Dimensions:	Approx. 2.0" X 3.0" X 5.75"
Weight:	Approx. 1.2 Lbs (0.55 Kg)
Mounting:	Panel Mount via Dzus fastners
Operating Temperature Range:	-45°C to +70°C
Power Requirement:	
Voltage:	28.0 Vdc, \pm 15%
Current:	1 .0 A Max.
Communications:	ASCII
Speed:	9600 baud
Parity:	None
Data:	8 bits
stop:	1 bit

SECTION 2

OPERATING INSTRUCTIONS

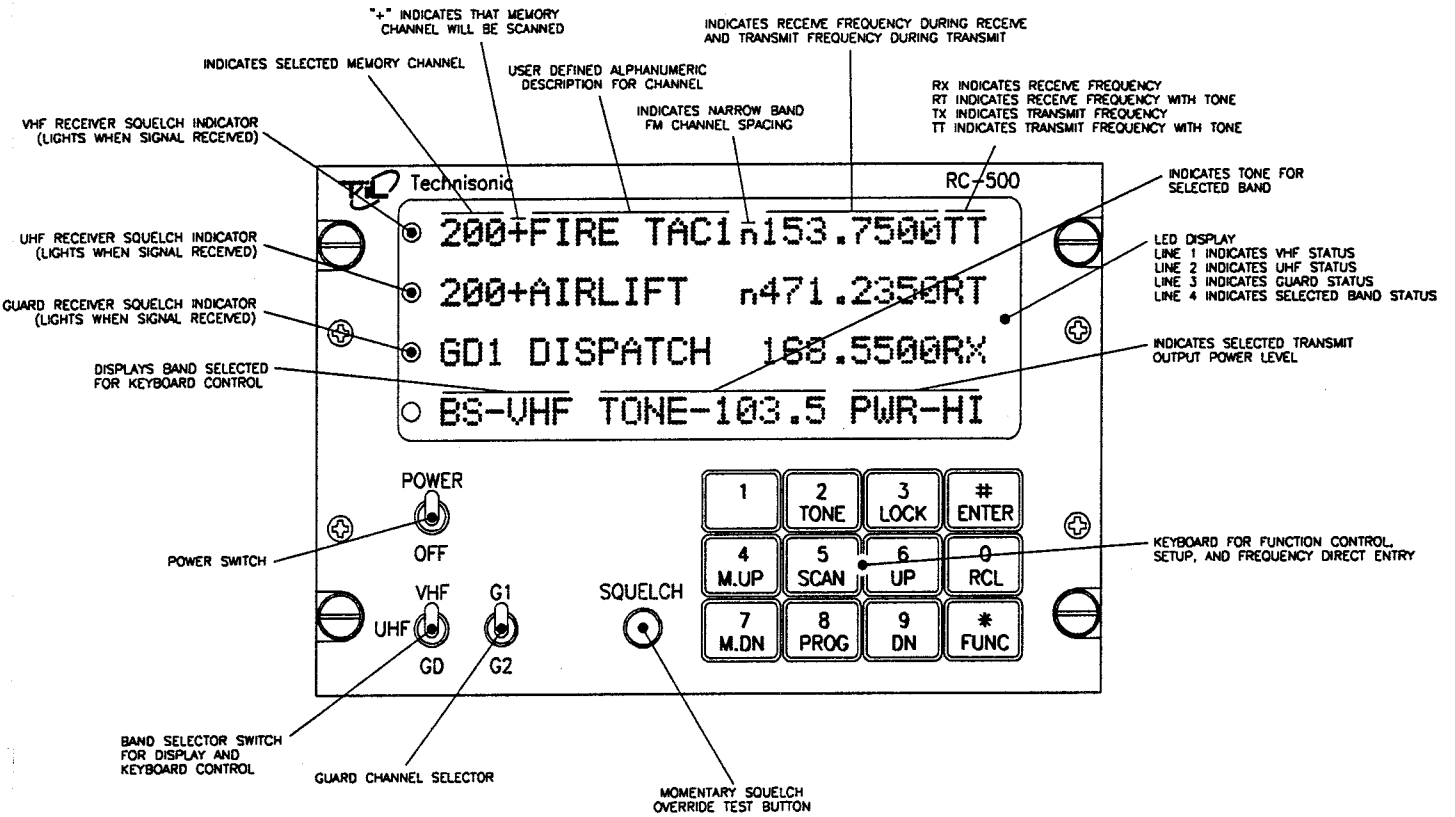

FIGURE 2-1 Model RC-500 Operator's Switches and Controls

2.2 OPERATING INSTRUCTIONS (See Figure 2-1)

These instructions assume knowledge of the TFM-500 operation. Please refer to Technisonic document No. 98RE243, Rev. N/C, Issue 5 for complete TFM-500 operating instructions.

1. **Switch power on to both the TFM-500 and the RC-500. It does not matter which one is switched on first. The RC-500 display will show the same information as on the TFM-500 radio except for what is affected by the Band Select and G 1 /G2 switches. The TFM-500 is in no way dependent on the RC-500 which may be turned off and on or just left off at any time without affecting the operation of the TFM-500. Mic signal, Headphone audio and PTT are supplied to the remote operator's position via an audio panel, therefore the RC-500 remote control head does not need to be on for the remote operator to transmit or receive on the TFM-500 radio. Remote frequency channelling and programming of the TFM-500 will require the RC-500.**

2. **When the TFM-500 is in normal operating mode, the functionality of the RC-500 is the same as it is on the radio except for the following:**
 - a) **The volume levels can not be adjusted from the RC-500.**
 - b) **The RF output power can not be switched at the remote, however the current power selection on the TFM-500 is displayed on the RC-500.**
 - c) **The band select switch determines what the status line on the RC-500 will display as well as selects which band will be affected during a program function but it is the band select switch on the TFM-500 that determines which band is selected for transmit.**
 - d) **Scanning can not be invoked by the RC-500 but it can be cancelled.**
 - e) **DTMF dialling is not available at the RC-500 keypad.**
 - f) **Dimming of the backlighting and the display is independent from the TFM-500 so that it can be adjusted to the local lighting conditions.**
 - g) **The frequency can not be scrolled in the variable frequency mode.**
 - h) **Crossband repeat can not be invoked.**
 - i) **The PTT timeout timer can not be changed.**
 - j) **The keyboard lockout function is independent from the TFM-500 so that both keypads don't lock at one user's request.**

3. **Programming of memory channels, CTCSS tones and DPL/DCS codes uses the identical procedure as the TFM-500.**

SECTION 3

INSTALLATION INSTRUCTIONS

3.1 GENERAL

This section contains information and instructions for the correct installation of the RC-500 remote control head.

3.2 EQUIPMENT PACKING LOG

Unpack the equipment and check for any damage that may have occurred during transit. Save the original shipping container for returns due to damage or warranty claims. Check that each item on the packing slip has been shipped in the container. Verify that the equipment display and backlighting configuration are the same as those ordered.

3.3 TRANSCEIVER INSTALLATION

The RC-500 remote control head is designed to be Dzus mounted and should be installed in conjunction with a IN-RC5 installation kit (P/N 999092-1). See Figure 3-1 for an outline drawing of the unit with dimensions to facilitate the installation.

3.4 INSTALLATION KIT - CONTENTS

The IN-RC5 installation kit consists of:

1. One 9 pin Cannon D mating connector (male) complete with crimp pins and hood.

3.5 INSTALLATION - PIN LOCATIONS AND CONNECTIONS

The pin numbers and locations for the 9 pin Cannon D located on the rear of the RC-500 transceiver are shown below. Pin connections are provided in TABLE 3-1.

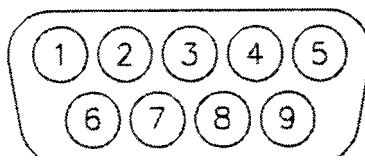

RC-500 Control head mounted view of 9 pin female connector

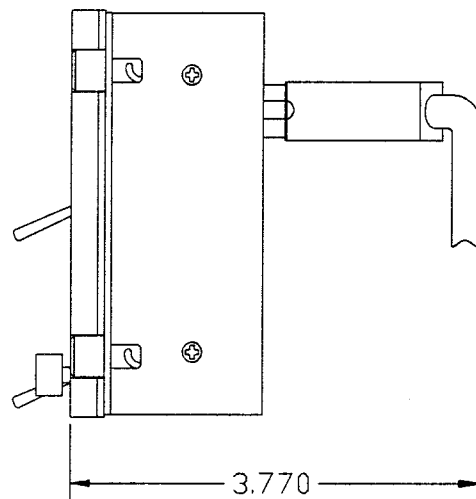
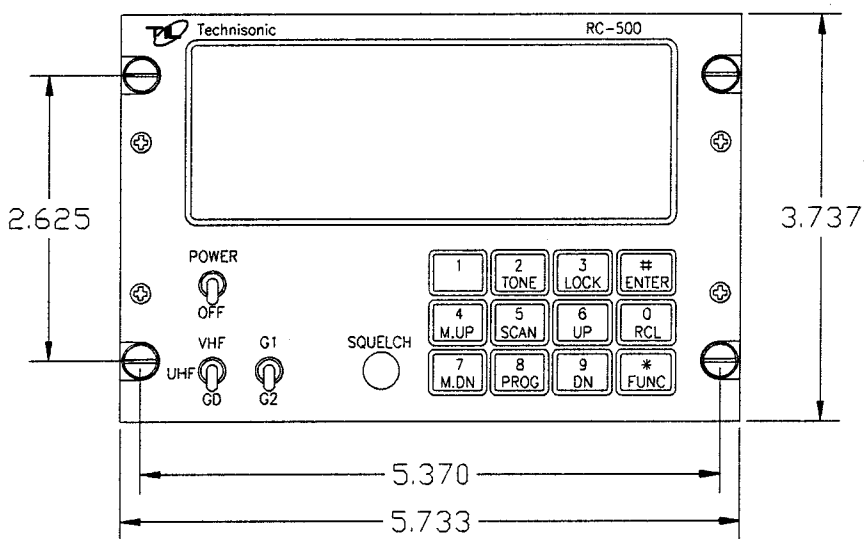
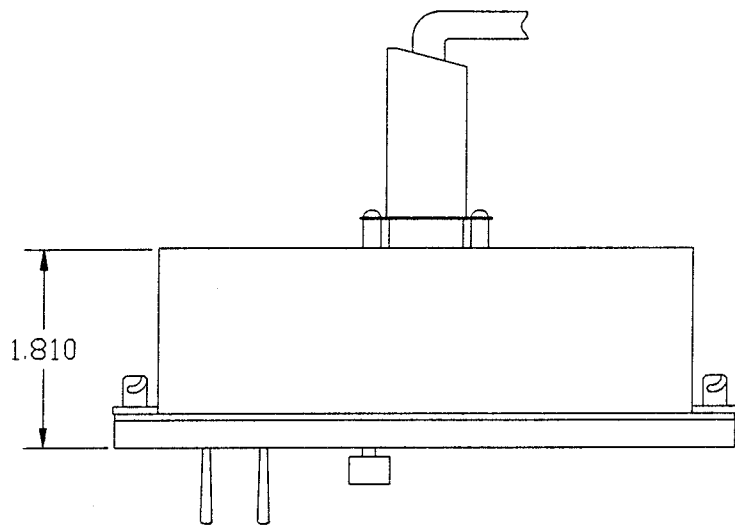
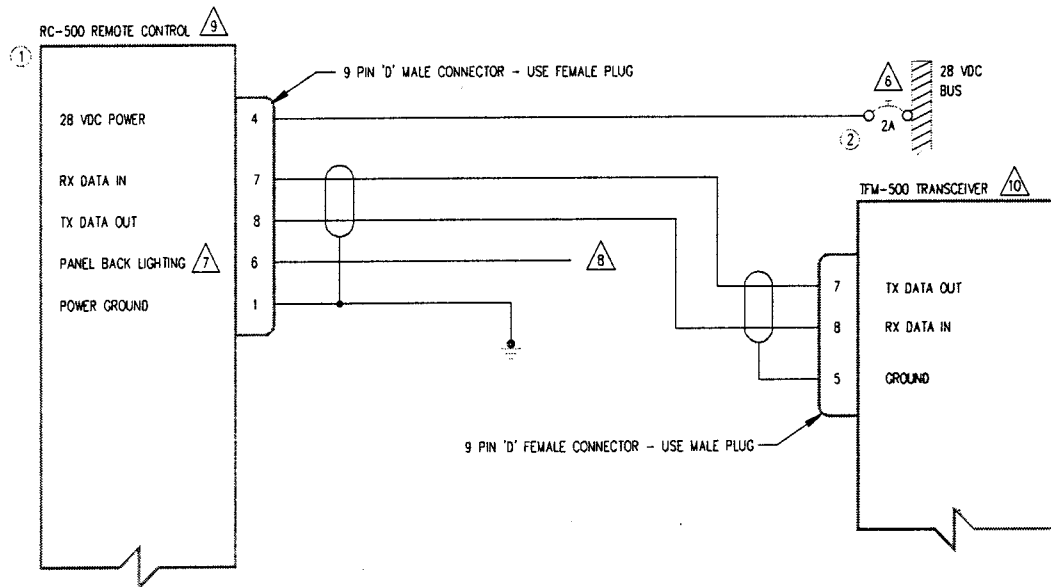

FIGURE 3-1 Outline Drawing for Model RC-500 Remote Control

3.6 INSTALLATION - PIN LOCATIONS AND CONNECTIONS (continued)

9 Pin D Connections - Use MALE Connector	
<u>Pin #</u>	<u>Description</u>
1	Ground
2	Background
3	Reset
4	+ 28 volts
5	N/C
6	Back lighting
7	RX Data In
8	TX Data Out
9	Vprog

TABLE 3-1



QTY	ITEM	PART NUMBER	DESCRIPTION	SPEC	MATERIAL
1	1	TFM-500	VHF/FM COMMUNICATIONS TRANSCEIVER.	TECHNISONIC INDUSTRIES LIMITED	
1	2	7274-11-5	CIRCUIT BREAKER, 2 AMPS	KLIXON	

NOTES:

- 1) ALL WIRE IAW MIL-W-22759 UNLESS OTHERWISE SPECIFIED.
- 2) ALL CABLE IAW MIL-C-27500 UNLESS OTHERWISE SPECIFIED.
- 3) FABRICATION & INSTALLATION OF WIRING HARNESS IAW AC 43.13-1A CHAPTER 11, SECTION 3, PARA 445 TO 462 AND SECTION 7.
- 4) GROUNDING AND BONDING IAW AC 43.13-1A CHAPTER 11, SECTION 3, PARA 452.
- 5) ALL SINGLE WIRE TO BE #22 AWG MINIMUM AND ALL SHIELDED WIRE TO BE #24 AWG MINIMUM, UNLESS OTHERWISE SPECIFIED.

6 AN EQUIVALENT CIRCUIT BREAKER OR FUSE MAY BE USED.

7 THE RC-500 IS AVAILABLE WITH 28V OR 5V PANEL LIGHTING. CHECK THE CONFIGURATION CONTROL LABEL FOR THE CORRECT VOLTAGE.

8 CONNECT TO THE APPROPRIATE AIRCRAFT DIMMING BUSS.

9 INSTALLATION OF REMOTE CONTROL IAW AC 43.13-1A CHAPTER 2, SECTION 3 AND AC 43.13-2A, CHAPTER 2, PR 3 1/2 DZUS RAIL OR EQUIVALENT MAY BE USED.

10 INSTALLATION OF TRANSCEIVER IAW AC 43.13-1A CHAPTER 2, SECTION 3 AND AC 43.13-2A, CHAPTER 2, PR 3 1/2 DZUS RAIL OR EQUIVALENT MAY BE USED.

11) TEST THE SYSTEM IN ACCORDANCE WITH THE POST-INSTALLATION TEST PROCEDURE IN THE INSTALLATION AND OPERATING INSTRUCTIONS MANUAL.

12) REFER TO THE AIRCRAFT STRUCTURAL REPAIR MANUAL AND THE MAINTENANCE MANUAL FOR INSTRUCTIONS AND INFORMATION PERTINENT TO THIS INSTALLATION.

13) THE USE OF RED DISPLAYS SHOULD BE MINIMIZED OR AVOIDED SO AS NOT TO DETRACT FROM THE ATTENTION GETTING CHARACTERISTICS NEEDED IN WARNING AND CAUTION ANNUNCIATORS. RED SHOULD BE USED TO ANNUNCIATE EMERGENCY CONDITIONS REQUIRING IMMEDIATE RESPONSE BY THE FLIGHT CREW. UNITS WITH RED DISPLAYS SHOULD NOT BE LOCATED IN CLOSE PROXIMITY TO WARNING AND CAUTION ANNUNCIATORS. THE INSTALLATION OF UNITS WITH RED DISPLAYS MUST BE EVALUATED ON A CASE BY CASE BASIS TO ENSURE THAT THE EFFECTIVENESS OF THE WARNING AND CAUTION ANNUNCIATORS IS NOT ADVERSELY AFFECTED.

FIGURE 3-2 Wiring connections for the RC-500 Remote Control.

3.7 WIRING INSTRUCTIONS

Figure 3-2 shows all required connections and recommended wire sizes for the RC-500.

3.7.1 Main Power + 28VDC

The main power + 28VDC ($\pm 15\%$) is connected to pin 4. Connect to a 2 amp breaker.

3.7.2 Main Ground

Ground connection for the RC-500 is on pin 1.

3.7.3 N/C

There is no connection to pin 5.

3.7.4 Back Lighting

Front panel back lighting connection should be made on pin 6. The opposite end of this lead should be connected to the panel lighting system of the aircraft. Before connecting, verify the required panel lighting voltage (28 VDC or 5VAC) on the configuration control label.

3.7.5 RX Data In

Data from the TFM-500 is received on pin 7.

3.7.6 TX Data Out

Data is sent to the TFM-500 from pin 8.

3.7.7 Background

Pin 2. This is the data line used during software upgrades at the factory and should be left unconnected.

3.7.8 Reset

The reset line on pin 3 is used during software upgrades at the factory and should be left unconnected.

3.7.9 Vprog

Programming voltage input on pin 9. This line is also only used during software upgrades at the factory and should be left unconnected.

APPENDIX TO “INSTALLATION INSTRUCTIONS” POST INSTALLATION EMI TEST

PURPOSE

The purpose of this test is to identify any interference that the RC-500 remote control head may cause with existing aircraft systems.

TEST CONDITIONS

The RC-500 should be installed and function tested. The TFM-500 transceiver should be on throughout this test.

METHODOLOGY

Most of the EMI tests can be accomplished on the ground.

The GPS should be operational and navigating with at least the minimum compliment of satellites. The VHF comm should have the squelch open. VOR/DME receivers should be selected for display. If possible, set up a DME/Transponder ramp test set and adjust the output until the flags are out of view. The transponder and encoder should be monitored with ramp test equipment. Set the output of the transponder test set to 3db above the output necessary to achieve 90% reply. If possible set the ADF to a nearby navigation station.

Switch the RC-500 on and off as often as required.

Observe the GPS for any degradation in satellite status or availability or flags. Listen for any noise or detected audio signals on the VHF comm(s). Listen for any noise or detected audio signals on the VOR/LOC receiver audio; look for any moment of flags or needles on the VOR/LOC/GS navigation display(s).

List the power plant, fuel and other electric instruments not already in the chart provided and note any anomalies that occur due to operation of the RC-500. Assess the results.

If the aircraft is equipped with an autopilot or a stability augmentation system, then test fly the aircraft and verify that operation of the RC-500 does not have adverse effects on these systems. After checking for gross effects at a safe altitude, fly a coupled ILS approach and look for any anomalies.

RESULTS

If the installed system passes all of the applicable EMI tests, then no further action is required. If interference is observed then the interference must be assessed against the appropriate standards of airworthiness for the system in question. A complete discussion of all the standards of airworthiness to be applied in assessing EMI effects is beyond the scope of this document.

PROCEDURE

List the power plant, fuel and other electric instruments not already included in the chart below and note any anomalies that occur due to operation of the RC-500. Assess the results.

STEP	SYSTEM	PASS	FAIL	NOTES
1	Com 1&2			
2	Transponder & Encoder			
3	ADF 1 & 2			
4	VG			
5	Glideslope 1&2			
6	VOR/LOC 1&2			
7	Compass			

STEP	SYSTEM	PASS	FAIL	NOTES
8	Directional Gyro			
9	Fuel Pressure			
10	Oil Temp			
11	Amps			
12	Bus Voltage			
13	Fuel %			
14	Ng			
15	TOT			

STEP	SYSTEM	PASS	FAIL	NOTES
16	Torque %			
17	Annunciators			
18	Digital Clock			
19	Oil Pressure			
20	DME			
21	GPS			
22	Autopilot			
23	Stability Augmentation System			

STEP	SYSTEM	PASS	FAIL	NOTES
24	Coupled ILS Approach			
NOTES:				