

SYSTEM 55 AUTOPILOT

Pilot's Information Manual

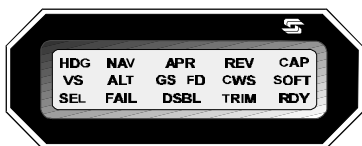

THIS MANUAL IS FOR INFORMATION ONLY. NOT APPROVED FOR COCKPIT USE.

Table of Contents

General Introduction	3
System Schematic	4
List of Acronyms	5
Modes of Operation	6
Preflight Procedures	
A. Autopilot	7
B. Optional Autotrim	8
Normal Operating Procedures	
A. Control Wheel Steering	10
B. Heading Mode	11
C. NAV Intercept/Tracking (Standard DG)	12
Selectable Intercept Angle(s)	14, 28, 47
D. NAV Intercept/Tracking (Optional HSI)	15
Selectable Intercept Angle(s)	16, 36, 54
E. Approach (APR) Mode Switch	17
F. Vertical Speed (VS)	19
G. Altitude Mode (ALT)	20
H. Pitch Trim Indicator	20
I. Autotrim (Optional)	21
J. Procedure Turn Localizer Approach (Std DG)	23
K. Localizer Intercept/Tracking (Standard DG)	26
L. Procedure Turn Localizer Approach, Optional HSI	31
M. Localizer Intercept/Tracking (Optional HSI)	34
N. Glideslope Intercept/Tracking	38
O. Procedure Turn Back Course Approach(Std DG)	43
P. Localizer Back Course Intercept/Track (Std DG)	46
Q. Procedure Turn Back Course Approach (Opt HSI)	50
R. Localizer Back Course Intercept/Track (Opt HSI)	53
S. Flight Director Operation (Optional)	57
System Failure and Caution Annunciations	60
Autopilot Disconnect	61
System Specifications	62

Introduction

The primary purpose of the **System 55 Pilot Information Manual (PIM)** is to provide potential S-TEC Autopilot buyers with step-by-step Functional Preflight and In Flight Operating procedures for the system.

NOTE

**This manual is for information only.
Not approved for cockpit use.**

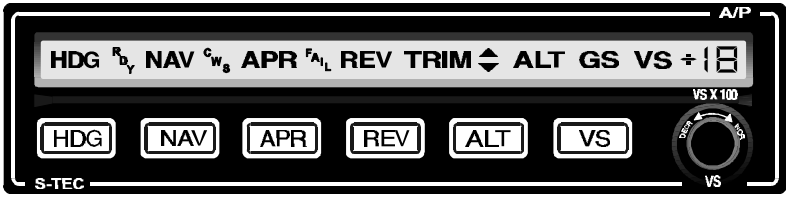

SYSTEM 55 SCHEMATIC

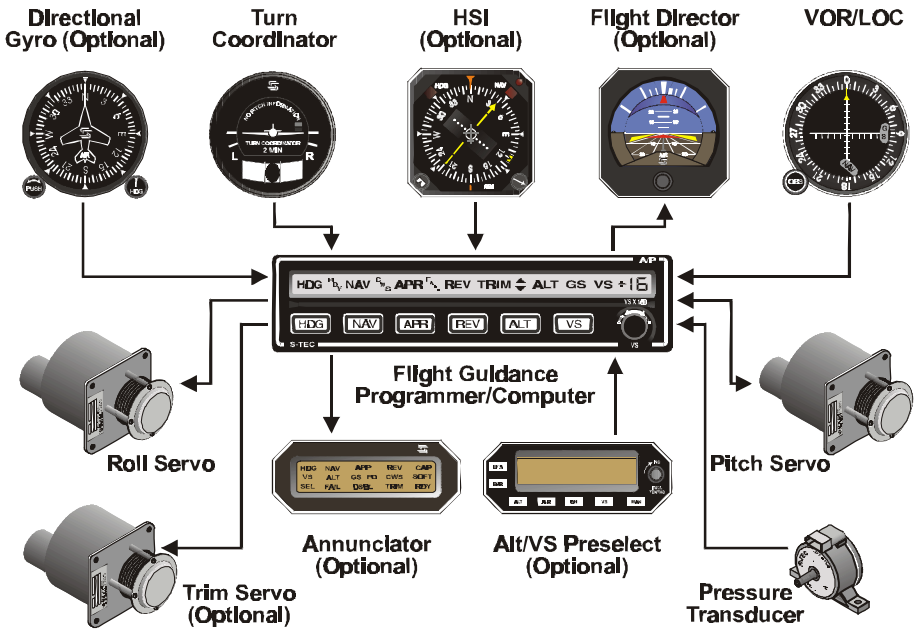

Acronyms Used in This Manual

ALT	Altitude
AFMS	Airplane Flight Manual Supplement
A/P	Auto Pilot
CB	Circuit Breaker
CDI	Course Deviation Indicator
CWS	Control Wheel Steering
DG	Directional Gyro
FAA	Federal Aviation Administration
GPS	Global Positioning System
HD	Heading
Hg	Mercury
HSI	Horizontal Situation Indicator
HI-TRK	High Gain Tracking
IFR	Instrument Flight Rules
IFP	In Flight Procedures
IMC	Instrument Meteorological Conditions
LOC	Localizer
LORAN	Long Range Navigation
LO-TRK	Low Gain Tracking
NAV	Navigation
OBS	Omnibearing Selector
PIM	Pilot Information Manual
PSI	Pounds Per Square Inch
RDY	Ready
SFM	Supplemental Flight Manual
ST	Stabilizer
TSO	Technical Standard Order
VFR	Visual Flight Rules
VMC	Visual Meteorological Conditions
VOR	Very High Frequency Omnidirectional Radio Range

SYSTEM 55 MODES OF OPERATION

The **System 55 Flight Guidance Programmer/Computer** serves the function of converting pilot commands to logic signals for the roll and pitch computer functions. As the pilot enters the desired mode by pressing the appropriate mode selector switch, the computer acknowledges the mode, causing the appropriate annunciator to illuminate.

The Roll Computer receives signal inputs from the Directional Gyro or optional H.S.I., VOR/LOC, RNAV, Loran or GPS Deviation Indicators and the Turn Coordinator. It computes roll servo commands for stabilization, turns, radio intercepts and tracking.

The pitch computer receives signal inputs from the altitude pressure Transducer, Accelerometer, Glideslope Deviation Indicator and Vertical Speed Modifier Control or optional Altitude Selector/Alerter or Altitude/Vertical Speed Selector. It computes pitch servo commands for vertical speed, altitude hold and glide slope intercept and tracking. Sensing for trim annunciation or optional automatic elevator trim is provided by the pitch servo. Drive for the optional elevator trim servo is provided by the pitch computer.

SYSTEM 55 PREFLIGHT PROCEDURE

The System 55 incorporates a **SELF TEST** which must pass before the autopilot can be engaged. To perform the test, aircraft D.C. electrical power must be on and supplied to the autopilot.

Place the **AUTOPILOT MASTER** switch to the **ON** position and observe that all segments of the Programmer/Computer display and optional Annunicator, if installed, illuminate for 5 seconds during the test.



Satisfactory completion is indicated by only **RDY** remaining on at the conclusion of the 5 second test.

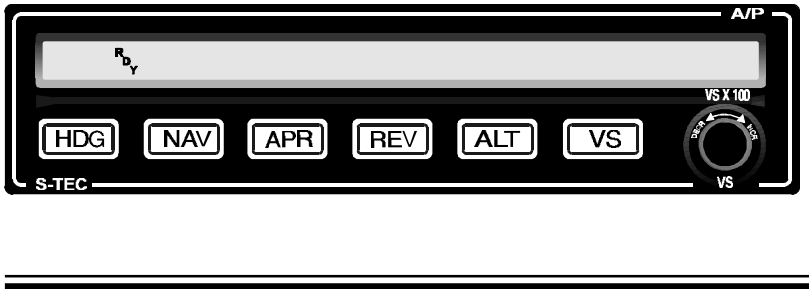

Should a fault be detected, the **FAIL** annunciation will remain on at the conclusion of the test and the autopilot can not be engaged.

If the the autopilot detects the Turn Coordinator rotor speed as low or not turning, the display will remain blank, and the autopilot can not be engaged.

If this condition occurs, you should consult your dealer before other use of the autopilot is attempted.

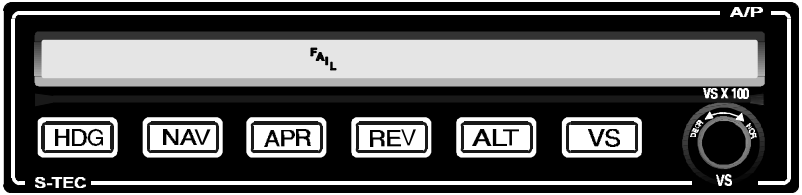

Preflight Test Without Optional Autotrim

Center the control wheel. Press and release the **Control Wheel Steering (CWS)** switch. **CWS** and **VS** should annunciate. Move the aircraft control wheel in both the roll and pitch axes to overpower the autopilot servos. Control motions should be smooth, without looseness or free play. Press the control wheel **Disconnect** switch. **RDY** will flash then annunciate steady. An audible tone should be heard indicating the autopilot disconnect. Move the aircraft controls to ensure freedom and confirm the autopilot has disconnected. If optional autotrim is not installed, this concludes the preflight test.

Preflight Test With Optional Autotrim

With the aircraft controls centered, grasp the control wheel and press and release the **Control Wheel Steering (CWS)** switch. **CWS** and **VS** should annunciate. Push forward on the control wheel. After about 3 seconds, trim should run "nose up". Pull control wheel aft. After about 3 seconds, trim should move "nose down". Move the aircraft control wheel in both the roll and pitch axes to overpower the autopilot servos. Control motions should be smooth, without looseness or free play. Move **Manual Trim Switch** up and down. The autopilot should disengage. **RDY** will flash then annunciate steady. Trim should operate in the commanded direction. (The **Trim Switch** will disengage the autopilot only when a pitch mode is engaged.) Re-engage **CWS** mode and press the **Trim Interrupt/AP Disconnect** switch. The autopilot should disengage. **RDY** will flash, then annunciate steady. An audible tone should be heard indicating the autopilot disconnect.

Retrim aircraft for takeoff and check controls for freedom of movement. Be sure the autopilot and trim are disengaged.

NOTE: IF EITHER THE MANUAL ELECTRIC TRIM OR AUTOTRIM FAILS ANY PORTION OF THE PREFLIGHT TEST, TURN THE TRIM MASTER SWITCH OFF. DO NOT USE THE ELECTRIC TRIM UNTIL THE FAULT IS CORRECTED. WITH TRIM MASTER SWITCH OFF, THE AUTOPILOT TRIM INDICATORS AND AUDIO WARNING ARE ACTIVATED. IF THE ELECTRIC TRIM FAILS, OR HAS AN IN-FLIGHT POWER FAILURE, THE SYSTEM AUTOMATICALLY REVERTS TO OUT-OF-TRIM ANNUNCIATION AND AUDIO WARNING. SHOULD THIS OCCUR, TURN THE TRIM MASTER SWITCH OFF, AND REVERT TO MANUAL TRIM UNTIL THE FAULT IS CORRECTED.

S-TEC SYSTEM 55 NORMAL OPERATING PROCEDURES

In order to activate any mode, the autopilot master switch must be in the **ON** position and the **RDY** annunciator must be illuminated.

CONTROL WHEEL STEERING (CWS)

Your new System 55 has a very desirable mode of operation - **Control Wheel Steering (CWS)**. This feature is the quickest way to engage both the Roll and Pitch Axes of the System and synchronize the autopilot with the present aircraft attitude.



Depress and hold the **Control Wheel Steering** switch located on the aircraft's control wheel. The **CWS** and **VS** modes will annunciate and **RDY** will extinguish. Position the aircraft in the desired roll and pitch attitude. Note: Aircraft vertical speed x 100 will be displayed in the Programmer/Computer Annunciator window directly above the VS selector knob. Example: + 6 equals 600 FPM rate of climb.

Allow the aircraft to stabilize in the desired attitude for 2 to 3 seconds, release the Control Wheel Steering switch and the autopilot roll and pitch servos will engage synchronized with the Aircraft's turn rate and vertical speed.

NOTE: IF THE AIRCRAFT ROLL ANGLE IS GREATER THAN A STANDARD RATE TURN WHEN THE CWS SWITCH IS RELEASED, THE BANK ANGLE WILL BE REDUCED TO PRODUCE 90% OF A STANDARD RATE TURN AS A MAXIMUM.

From the **CWS** mode, the pilot may select other modes such as **HDG**, **NAV**, **ALT** or may modify the present vertical speed using the **VS** knob.

The pilot may re-enter the **CWS** mode at any time by simply depressing the **CWS** switch on the control wheel, positioning the aircraft in the desired roll and pitch attitude and releasing the **CWS** switch. NOTE: After initial autopilot engagement when the **CWS** switch is depressed, the roll and pitch servos will be disengaged during the maneuvering phase. An audible tone will be heard indicating servo disengagement.

HEADING MODE

Heading (HDG) mode may be selected initially from **CWS** mode or **RDY** mode. Set the heading bug on the DG or optional HSI to the desired heading, and press the **HDG** switch. The **HDG** annunciator will illuminate. New headings can be selected simply by repositioning the heading bug.

A reminder: When operating in the **HDG** mode, the system is not coupled to any navigation aid. It merely flies a specific heading. It will be necessary to monitor navigation instruments for course deviation due to wind drift, and to establish wind correction angles.



NAV Intercept and Tracking (with Standard DG)

To intercept and track a VOR, RNAV, Loran or GPS course, tune the Navigation Radio receiver to the proper frequency and select the desired course. Move the heading bug in the direction of desired travel to match the selected course.



Engage the **NAV** mode. If the course needle is at full-scale deviation, the autopilot will establish a 45° intercept angle. As the aircraft approaches the selected course, the autopilot senses the closure rate, and gradually, smoothly shallows the intercept angle. The point at which this turn begins is variable, depending on the aircraft position and closure rate to the course. However, the turn will always begin between 100% (full-scale) needle deflection and 20% of full-scale.

During the intercept sequence, the system operates in maximum gain and sensitivity to needle position and motion; 90% of standard rate turn. When the selected course is intercepted, and the needle is centered, indicating course capture, initiation of the tracking gain program is automatic.



If the aircraft is equipped with the optional Annunciator, the **NAV** and **CAP** modes will be annunciated.

The high sensitivity level is maintained for about 15 seconds while wind correction angle is established. Turn rate maximum is then reduced to 45% standard rate.



The optional remote Annunciator will indicate *NAV*, *CAP* and *SOFT*.

Approximately 60 seconds later, the turn rate maximum is reduced to 15% of standard rate and the lowest level of sensitivity is achieved.

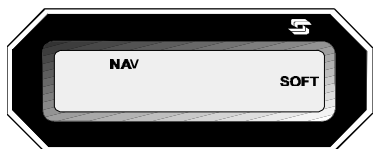

At this point the optional remote Annunciator will indicate *NAV* and *SOFT*. The *CAP* annunciation will extinguish.

If the Heading bug is within 5° of center and needle deflection is less than 10%, the computer will immediately establish this lowest sensitivity level when *NAV* is selected.

This condition provides low activity levels during station passage when VOR signals are erratic. In other words, it ignores short-term needle excursion.

The system includes a course deviation monitor. If the aircraft strays off course or LOC centerline by 50% needle deflection, the *NAV* annunciator flashes a warning. It flashes at station passage because of short-term needle excursion, and because the NAV signal is inadequate. It also flashes when the OBS NAV flag is displayed. When that occurs, the *FAIL* annunciation will illuminate.

When operating in the *NAV/SOFT* mode, and needle deflection of 50% or more is experienced for 1.5 minutes, the gain program will switch to *NAV/CAP/SOFT*, increasing sensitivity and authority to re-establish the aircraft on course.

When a course change of 10° or more is required at an en route VOR, select the new course, and reset the **NAV** mode to reinstate the capture sequence. Set the DG heading bug to the new course.

PILOT SELECTABLE INTERCEPT ANGLE (S)

The pilot may select an angle of intercept less than the standard 45°. Simply place the heading bug on the D.G. to the desired heading to be used for the course intercept and push both **HDG** and **NAV** switches simultaneously. Both **HDG** and **NAV** will be annunciated.



The selected heading will now be flown until the autopilot computes that an on course turn must be made to minimize overshoot at the point of intercept. At the time the on course turn begins, the **HDG** mode will extinguish and you must move the heading bug to match the selected radio course. This will allow the autopilot the full range of cross wind correction during **NAV** track mode.



NOTE: INTERCEPT ANGLES GREATER THAN 45° USUALLY RESULT IN SOME COURSE OVERTHOOT, DEPENDING ON THE DISTANCE FROM THE STATION AND AIRCRAFT SPEED. THEREFORE, ANGLES GREATER THAN 45° ARE NOT RECOMMENDED.

NAV INTERCEPT AND TRACK (OPTIONAL H.S.I.)

If your aircraft is equipped with an optional Horizontal Situation Indicator, your S-TEC autopilot will receive both left/right deviation and course information when the course selector is set to the desired course. With an H.S.I., the heading bug is not used during tracking.

To intercept and track a VOR, RNAV, LORAN or GPS Course, select the desired course with the H.S.I. Course Selector and engage the **NAV** mode.



If the course needle is at full-scale deviation, the autopilot will establish a 45° intercept angle. As the aircraft approaches the selected course, the autopilot senses the closure rate, and gradually, smoothly shallows the intercept angle. The point at which this turn begins is variable, depending on the aircraft position and closure rate to the course. However, the turn will always begin between 100% (full-scale) needle deflection and 20% of full-scale.

During the intercept sequence, the system operates in maximum gain and sensitivity to needle position and motion: 90% of standard rate. When the selected course is intercepted, and the needle is centered, indicating course capture, initiation of the tracking gain program is automatic.

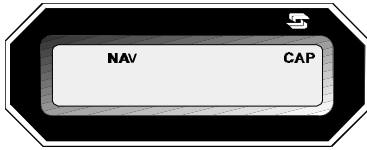

If the aircraft is equipped with the optional annunciator, the *NAV* and *CAP* modes will be annunciated.

The high sensitivity level is maintained for about 15 seconds while wind correction angle is established. Turn rate maximum is then reduced to 45% standard rate.

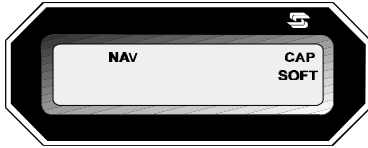

The optional remote annunciator will indicate *NAV*, *CAP* and *SOFT*.

Approximately 60 seconds later, the turn rate maximum is reduced to 15% standard rate and the lowest level of sensitivity is achieved.



At this point the optional remote annunciator will indicate *NAV* and *SOFT*. The *CAP* annunciation will extinguish.

If the course selector is within 5° of center and needle deflection is less than 10%, the computer will immediately establish this lowest sensitivity level when *NAV* is selected.

This condition provides low activity levels during station passage when VOR signals are erratic. In other words, it ignores short-term needle excursion.

The system includes a course deviation monitor. If the aircraft strays off course or LOC centerline by 50% needle deflection, the *NAV* annunciator flashes a warning. It flashes at station passage because of short-term needle excursion, and because *NAV* signal is inadequate. It also flashes when the H.S.I. NAV flag is displayed. When that occurs, the *FAIL* annunciation will illuminate.

When operating in the *NAV/SOFT* mode, and needle deflection of 50% or more is experienced for 1.5 minutes, the gain program will switch to *NAV/CAP/SOFT*, increasing sensitivity and authority to re-establish the aircraft on course.

When a course change of 10° or more is required at an en route VOR, select the new course, and reset the **NAV** mode to reinstate the capture sequence.

PILOT SELECTABLE INTERCEPT ANGLE (S)

The pilot may select an angle of intercept less than the standard 45°. Simply place the heading bug on the H.S.I. on the desired heading to be used for the course intercept and push both **HDG** and **NAV** switches simultaneously. Both *HDG* and *NAV* will be annunciated.



The selected heading will now be flown until the autopilot computes that an on course turn must be made to minimize overshoot at the point of intercept. At the time the on course turn begins, the *HDG* mode will extinguish.



NOTE: INTERCEPT ANGLES GREATER THAN 45° USUALLY RESULT IN SOME COURSE OVERTHOOT, DEPENDING ON THE DISTANCE FROM THE STATION AND AIRCRAFT SPEED. THEREFORE, ANGLES GREATER THAN 45° ARE NOT RECOMMENDED.

APPROACH (APR) MODE SWITCH

The **APR** mode provides increased sensitivity for VOR, LORAN, GPS or AREA NAV approaches. The pilot may also select this mode if increased sensitivity is desired for en route NAV tracking.

NAV and *APR* will be annunciated on the Programmer/Computer.

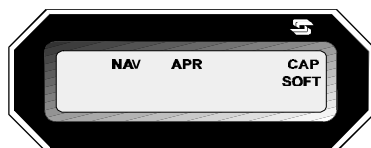

If the optional remote annunciator is installed, *NAV*, *APR*, *CAP* and *SOFT* will be annunciated.

VERTICAL SPEED (VS)

In order to engage vertical speed, the autopilot roll axis must be engaged. Selecting **CWS** mode or any roll mode will satisfy this requirement.

In **CWS** mode, the pilot may select the desired vertical speed in 100 ft increments by rotating the **VS** knob clockwise or counter clockwise.

With any roll mode engaged, the pilot may select the **VS** mode by pressing the **VS** mode select switch. The autopilot will synchronize with the aircraft's vertical speed at the time the mode is selected and the corresponding vertical speed will be indicated in the Programmer/Computer display. Vertical speed may now be modified in 100 ft increments by rotating the **VS** knob clockwise or counter clockwise.



The + (positive) symbol annunciation indicates a *climb* vertical speed selection. Clockwise rotation of the **VS** knob increases the rate of climb and counter clockwise rotation decreases the rate of climb to 0. The - (negative) symbol annunciation indicates a *descent* vertical speed selection. Counter clockwise rotation of the **VS** knob increases the rate of descent and clockwise rotation decreases the rate of descent to 0. Maximum selectable VS limits are ± 1600 FPM.



NOTE: IF THE **VS** MODE ANNUNCIATOR FLASHES, WHILE IN THE **VS** MODE, THIS IS AN INDICATION OF EXCESSIVE ERROR BETWEEN ACTUAL VERTICAL SPEED COMPARED TO SELECTED VERTICAL SPEED (USUALLY IN A CLIMB) AND THE PILOT SHOULD ADJUST AIRCRAFT POWER OR REDUCE THE VERTICAL SPEED COMMAND AS APPROPRIATE.

ALTITUDE (ALT)

The altitude hold mode, **ALT**, may be engaged with any roll mode, **CWS** mode or **VS** mode engaged, by pressing the **ALT** mode switch. The aircraft will maintain the pressure altitude present at the time of **ALT** mode selection.

Altitude Correction for en route barometric pressure changes may be made while in **ALT** mode by rotation of the **VS** knob. Each "Click" will change the altitude by 10 ft. The maximum altitude correction is ± 200 ft. Corrections in excess of ± 200 ft will require selecting the **VS** mode and climbing or descending to the new altitude and re-engaging **ALT** mode.

Pitch Trim Indicator

Without automatic trim or when trim is turned off, a sensor in the System 55 autopilot pitch servo detects out-of-trim elevator loads. When such forces exceed a preset level and time delay, **TRIM** will annunciate on the Flight Guidance Programmer/Computer with either the  (up) or  (dn) symbol annunciated to indicate the direction elevator trim is required. In addition, effective with unit serial number 321 and on, an audible warning tone will sound for 5 seconds. **NOTE: This is the same audible beeping tone emitted when the autopilot is disconnected but at a slower rate.** The annunciation will be steady for about 5 seconds, then flash until proper trim conditions have been met.

NOTE: IF TRIM IS ANNUNCIATED AND THE PILOT DISENGAGES THE AUTOPILOT, THERE WILL BE A RESIDUAL OUT OF TRIM FORCE AT THE CONTROL WHEEL. BE ALERT FOR THIS CONDITION IF THE AUTOPILOT IS DISENGAGED WHILE TRIM IS ANNUNCIATED.

OPTIONAL AUTOTRIM

If the autopilot is equipped with optional autotrim, the aircraft elevator trim will be maintained automatically when the trim master switch is on and a pitch mode is activated.

When the elevator trim is in motion, **TRIM** and the ▲ (up) or ▼ (dn) symbol will annunciate indicating trim in motion and direction of travel. Should the trim continue to run in excess of 7 seconds, these annunciations will flash.



If the trim master switch is OFF or a failure has occurred in the autotrim, the system will automatically revert to "Pitch Trim Indicator" mode of operation.

NOTE: USING THE TRIM SWITCH ON THE CONTROL WHEEL WHILE THE PITCH AXIS OF THE AUTOPILOT IS ENGAGED WILL DISCONNECT THE AUTOPILOT.

The autotrim option also provides the pilot with **Manual Electric Trim** when the autopilot is disengaged or if only a roll axis mode has been engaged.

To use manual electric trim, simply push the trim toggle switch, located on the aircraft's control wheel, in the desired direction of trim. **FORWARD** for nose down or **AFT** for nose up. **TRIM** will be annunciated and will flash while the trim is in motion.



The S-TEC trim system is designed to accept any type of single failure - mechanical or electrical - without uncontrolled operation resulting. To ensure that no hidden failures have occurred, conduct a trim preflight check prior to every flight.

Procedure Turn Localizer Approach (Standard D.G.)

Select the appropriate localizer frequency. Set the heading bug to the **OUTBOUND** localizer course and engage the **REV** mode to track the localizer front course outbound or back course inbound.

When a localizer is channeled and **REV** mode is selected, the System 55 will automatically execute high sensitivity gain for the approach and **REV** and **APR** will be annunciated.

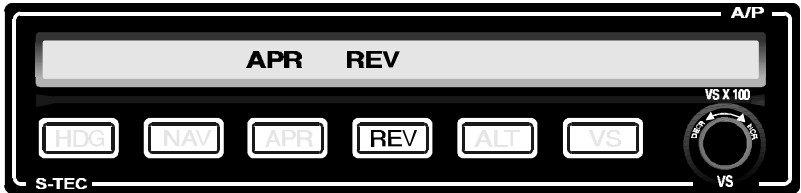

If the course needle is at full-scale deviation, the autopilot will establish a 45° intercept angle. As the aircraft approaches the localizer course, the autopilot senses the closure rate, and gradually, smoothly shallows the intercept angle. The point at which this turn begins is variable, depending on the aircraft position and closure rate to the course. However, the turn will always begin between 100% (full-scale) needle deflection and 20% of full-scale.

During the intercept sequence, the system operates in maximum gain and sensitivity to needle position and motion; 90% of standard rate turn. When the localizer course is intercepted, and the needle is centered, indicating course capture, initiation of the tracking gain program is automatic.



If the aircraft is equipped with the optional annunciator, the **REV**, **APR** and **CAP** modes will be annunciated.

The high sensitivity level is maintained for about 15 seconds while wind correction angle is established. Turn rate maximum is then reduced to 45% standard rate.



The optional remote annunciator will indicate **REV**, **APR**, **CAP** and **SOFT**.

If the heading bug is within 5° of center and needle deflection is less than 10%, the computer will immediately establish this sensitivity level when **REV** is selected.

Set the heading bug to the outbound procedure turn heading and select heading mode. At the appropriate time, in 90° increments, set the heading bug to the inbound procedure turn heading. Once established on the inbound procedure turn heading, follow the localizer intercept and tracking procedures for standard D.G.

Procedure Turn Localizer Approach and Tracking with Standard D.G.

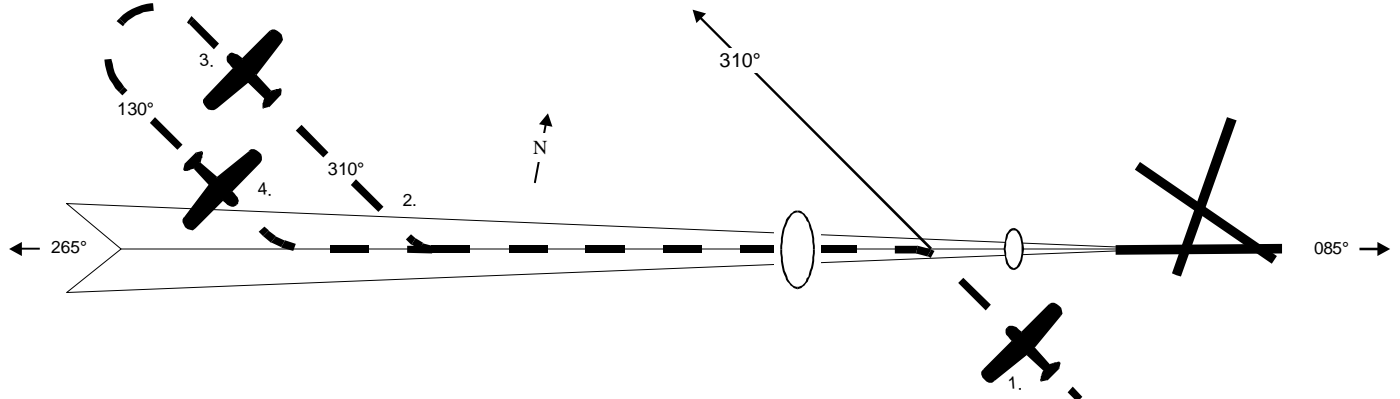

1. a. Tune navigation radio to LOC frequency.
b. Set heading bug to published outbound LOC heading.
c. Push **REV** mode switch.

2. a. Set heading bug to outbound procedure turn heading.
b. Press **HDG** mode switch.

3. a. In 90° increments, set heading bug to *inbound* procedure turn heading.

4. a. Set heading bug to inbound LOC heading.
b. Press **NAV** mode switch. Autopilot will intercept and capture localizer course and track inbound to the airport.

Localizer Intercept and Tracking (Standard D.G.)

With the appropriate localizer frequency selected, set the heading bug to the **INBOUND** localizer course and engage the **NAV** mode to track the localizer front course inbound or back course outbound.

When a localizer is channeled and **NAV** mode is selected, the System 55 will automatically execute high sensitivity gain for the approach and automatically activate the **APR** mode. **NAV** and **APR** will be annunciated.



If the course needle is at full-scale deviation, the autopilot will establish a 45° intercept angle. As the aircraft approaches the localizer course, the autopilot senses the closure rate, and gradually, smoothly shallows the intercept angle. The point at which this turn begins is variable, depending on the aircraft position and closure rate to the course. However, the turn will always begin between 100% (full-scale) needle deflection and 20% of full-scale.

During the intercept sequence, the system operates in maximum gain and sensitivity to needle position and motion: 90% of standard rate turn. When the localizer course is intercepted, and the needle is centered, indicating course capture, initiation of the tracking gain program is automatic.

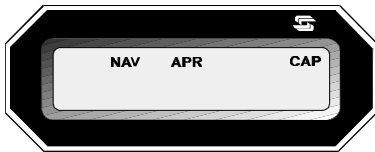

If the aircraft is equipped with the optional annunciator, the **NAV**, **APR** and **CAP** modes will be annunciated.

The high sensitivity level is maintained for about 15 seconds while wind correction angle is established. Turn rate maximum is then reduced to 45% standard rate.

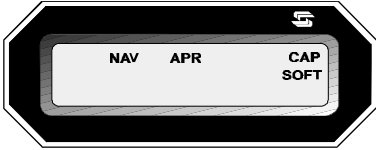

The optional remote annunciator will indicate *NAV*, *APR*, *CAP* and *SOFT*.

If the heading bug is within 5° of center and needle deflection is less than 10%, the computer will immediately establish this sensitivity level when *NAV* is selected.

The system includes a course deviation monitor. If the aircraft strays off LOC centerline by 50% needle deflection, the *NAV* annunciator flashes a warning. It also flashes when the OBS NAV flag is displayed. When that occurs, the *FAIL* annunciation will illuminate.

PILOT SELECTABLE INTERCEPT ANGLE (S)

The pilot may select an angle of intercept less than the standard 45°. Simply place the heading bug on the D.G. on the desired heading to be used for the course intercept and push both *HDG* and *NAV* switches simultaneously. *HDG*, *NAV* and *APR* will be annunciated.



The selected heading will now be flown until the autopilot computes that an on course turn must be made to minimize overshoot at the point of intercept. At the time the on course turn begins, the **HDG** mode will extinguish and you must move the heading bug to match the localizer course. This will allow the autopilot the full range of cross wind correction during **NAV**, **APR** track mode.

NOTE: INTERCEPT ANGLES GREATER THAN 45° USUALLY RESULT IN SOME COURSE OVERSHOOT, DEPENDING ON THE DISTANCE FROM THE STATION AND AIRCRAFT SPEED. THEREFORE, ANGLES GREATER THAN 45° ARE NOT RECOMMENDED.

Straight-in Localizer Approach and Tracking with Standard D.G.

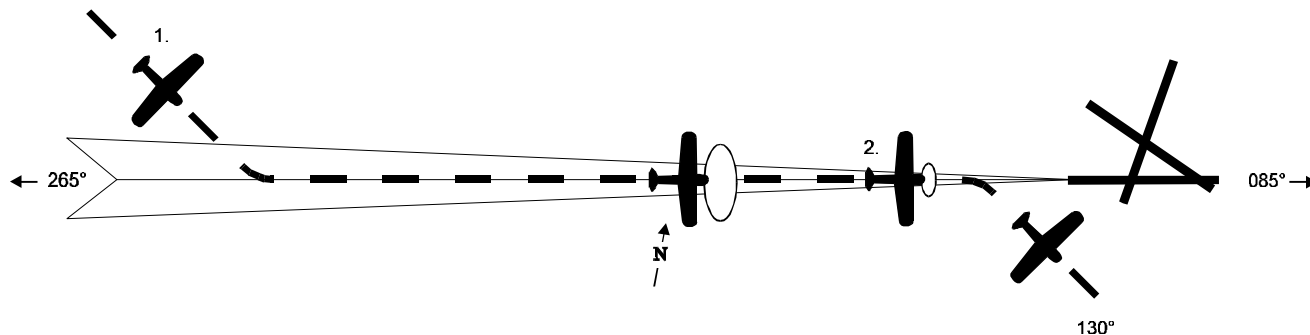

1. a. Tune navigation radio to localizer frequency.
b. Set HDG bug to published inbound course.
c. Press **NAV** mode switch. Autopilot will intercept, capture and track the localizer course.

2. If a missed approach is declared at the middle marker:
a. Disconnect the autopilot and stabilize the aircraft for the missed approach.
b. Set the HDG bug to the published missed approach heading.

c. Press the **HDG** mode switch.
d. Press the **VS** mode switch if desired.

NOTE
The pilot may elect to use **CWS** for stabilizing the aircraft for missed approach and then press **HDG** mode.

Procedure Turn Localizer Approach (Optional H.S.I.)

Select the appropriate localizer frequency. Set the course selector to the **INBOUND** localizer course and engage the **REV** mode to track the localizer front course outbound or back course inbound.

When a localizer is channeled and **REV** mode is selected, the System 55 will automatically execute high sensitivity gain for the approach and **REV** and **APR** will be annunciated.



If the course needle is at full-scale deviation, the autopilot will establish a 45° intercept angle. As the aircraft approaches the localizer course, the autopilot senses the closure rate, and gradually, smoothly shallows the intercept angle. The point at which this turn begins is variable, depending on the aircraft position and closure rate to the course. However, the turn will always begin between 100% (full-scale) needle deflection and 20% of full-scale.

During the intercept sequence, the system operates in maximum gain and sensitivity to needle position and motion: 90% of standard rate turn. When the localizer course is intercepted, and the needle is centered, indicating course capture, initiation of the tracking gain program is automatic.

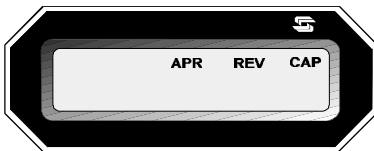

If the aircraft is equipped with the optional annunciator, the **REV**, **APR** and **CAP** modes will be annunciated.

The high sensitivity level is maintained for about 15 seconds while wind correction angle is established. Turn rate maximum is then reduced to 45% standard rate.

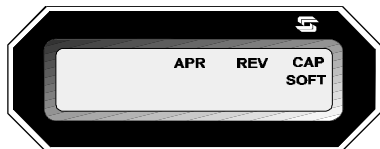

The optional remote annunciator will indicate *REV*, *APR*, *CAP* and *SOFT*.

If the course selector is within 5° of center and needle deflection is less than 10%, the computer will immediately establish this sensitivity level when **REV** is selected.

Set the heading bug to the outbound procedure turn heading and select heading mode. At the appropriate time, in 90° increments, set the heading bug to the inbound procedure turn heading. Once established on the inbound procedure turn heading, follow the localizer intercept and tracking procedures for optional H.S.I.

Localizer Intercept and Tracking (Optional H.S.I.)

With the appropriate localizer frequency selected, set the course selector to the **INBOUND** localizer course and engage the **NAV** mode to track the localizer front course inbound or back course outbound.

When a localizer is channeled and **NAV** mode is selected, the System 55 will automatically execute high sensitivity gain for the approach and automatically activate the **APR** mode. **NAV** and **APR** will be annunciated.



If the course needle is at full-scale deviation, the autopilot will establish a 45° intercept angle. As the aircraft approaches the localizer course, the autopilot senses the closure rate, and gradually, smoothly shallows the intercept angle. The point at which this turn begins is variable, depending on the aircraft position and closure rate to the course. However, the turn will always begin between 100% (full-scale) needle deflection and 20% of full-scale.

During the intercept sequence, the system operates in maximum gain and sensitivity to needle position and motion; 90% of standard rate turn. When the localizer course is intercepted, and the needle is centered, indicating course capture, initiation of the tracking gain program is automatic.

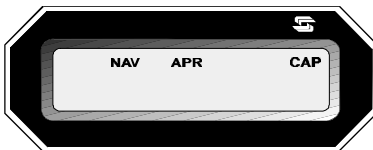

If the aircraft is equipped with the optional annunciator, the **NAV**, **APR** and **CAP** modes will be annunciated.

The high sensitivity level is maintained for about 15 seconds while wind correction angle is established. Turn rate maximum is then reduced to 45% standard rate.

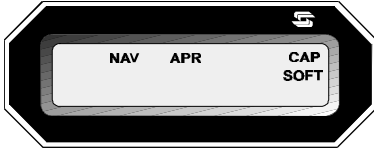

The optional remote annunciator will indicate *NAV*, *APR*, *CAP* and *SOFT*.

If the course selector is within 5° of center and needle deflection is less than 10%, the computer will immediately establish this sensitivity level when *NAV* is selected.

Since the heading bug is not used for the final approach segment, the pilot may elect to move the heading bug to the published missed approach heading for reference and use in the heading mode should a missed approach be necessary.

The system includes a course deviation monitor. If the aircraft strays off LOC centerline by 50% needle deflection, the *NAV* annunciator flashes a warning. It also flashes when the H.S.I. NAV flag is displayed. When that occurs, the *FAIL* annunciation will illuminate.

Pilot Selectable Intercept Angles

The pilot may select an angle of intercept less than the standard 45°. Simply place the heading bug on the desired heading to be used for the course intercept and push both **HDG** and **NAV** switches simultaneously. **HDG**, **NAV** and **APR** will be annunciated.



The selected heading will now be flown until the autopilot computes that an on course turn must be made to minimize overshoot at the point of intercept. At the time the on course turn begins, the **HDG** mode will extinguish.

NOTE: INTERCEPT ANGLES GREATER THAN 45° USUALLY RESULT IN SOME COURSE OVERSHOOT, DEPENDING ON THE DISTANCE FROM THE STATION AND AIRCRAFT SPEED. THEREFORE, ANGLES GREATER THAN 45° ARE NOT RECOMMENDED.

Straight-in Localizer Approach and Tracking, Optional HSI

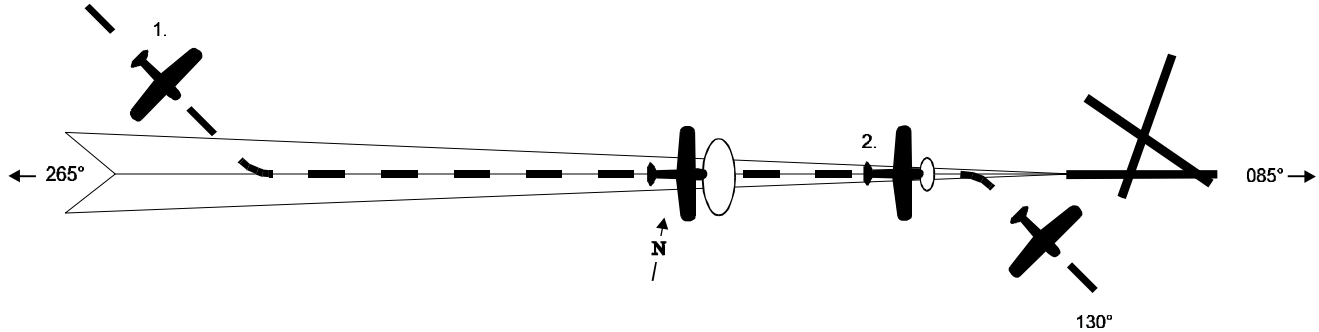

1. a. Tune navigation radio to LOC frequency.
- b. Set course pointer to published inbound LOC course heading.
- c. Press NAV mode switch.

2. a. Once NAV mode is established, heading bug can be set to published missed approach heading.

- b. At the middle marker, if a missed approach is declared, disconnect the autopilot and stabilize the aircraft for the missed approach before engaging HDG and VS modes.

NOTE
The pilot may elect to use CWS for stabilizing the aircraft for missed approach and then press HDG mode.

Glideslope Intercept and Tracking

To arm the automatic glideslope capture function, the following conditions must be met: (a) NAV receiver must be tuned to the appropriate frequency; (b) glideslope signal must be valid - no flag; (c) autopilot must be in *NAV/APR/ALT* modes; (d) aircraft must be 60% or more below the GS centerline during the approach to the intercept point, and within 50% needle deviation of the localizer centerline at the point of intercept - usually the outer marker.



Glideslope arming will occur when the above conditions have existed for 10 seconds. Illumination of the *GS* annunciator will occur, indicating arming has been accomplished. The *ALT* annunciator remains on.



Glideslope capture is indicated by extinguishing of the *ALT* annunciation.



NOTE: IF VECTORED TO INTERCEPT THE LOCALIZER TOO CLOSE TO THE GLIDESLOPE INTERCEPT POINT, RESULTING IN LESS THAN 60% GS NEEDLE DEVIATION WHEN ON COURSE, THE SYSTEM WILL NOT AUTOMATICALLY ARM THE GLIDESLOPE. MANUAL ARMING MUST THEN BE FOLLOWED.

Manual Arm/Automatic Capture

If approach vectoring locates the aircraft above or too near the glideslope centerline at the intercept point, usually the outer marker, it becomes necessary to execute manual arming of the glideslope. This is done by: (a) pressing the **ALT** switch **once** if operating in the altitude hold mode, and (b) pressing the **ALT** switch **twice** if operating in the *VS* mode. Once capture is achieved, the **GS** annunciation will illuminate, and the *ALT* annunciation will extinguish.

The system includes a Glideslope deviation monitor. If the aircraft strays off glideslope center line by 50% needle deflection, the **GS** annunciator flashes a warning. It also flashes when the GS flag is displayed. When that occurs, the *FAIL* annunciation will illuminate.

NOTE: IF IT BECOMES NECESSARY TO ESTABLISH A HOLDING PATTERN AT THE OUTER MARKER, AUTOMATIC GLIDESLOPE ARMING CAN BE DISABLED BY PRESSING THE NAV SWITCH A SECOND TIME WHILE IN THE NAV/APR MODE. THE **GS** ANNUNCIATOR WILL FLASH AND **ALT** WILL BE ANNUNCIATED. IF EQUIPPED WITH THE OPTIONAL REMOTE ANNUNCIATOR, THE **GS** ANNUNCIATOR WILL FLASH, AND THE **ALT** AND **DSBL** ANNUNCIATORS WILL ILLUMINATE, TO INDICATE THAT THE **GS** MODE IS DISABLED. TO RE-ESTABLISH GS ARMING, PRESS THE NAV MODE SWITCH AGAIN. THE **DSBL** CONDITION ANNUNCIATOR WILL EXTINGUISH, THE **GS** ANNUNCIATOR WILL CEASE TO FLASH, AND BE STEADY. REARMING WILL OCCUR WHEN ALL OTHER REQUIRED CONDITIONS STATED HAVE BEEN MET.

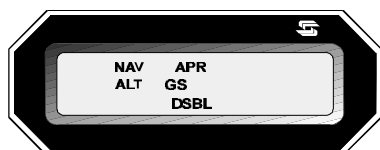

To fly the holding pattern, if inbound to the outer marker, press the **NAV** switch twice to disable the glideslope arming. When the outer marker or holding fix is reached, press the **HDG** switch, and rotate the heading bug in the direction of the turn. It is best to select the reciprocal course in increments of 90° , rather than the full 180° . When the outbound leg is completed, again rotate the HDG bug in the direction of the turn, in 90° increments, to re-establish the inbound course, and press the **NAV** switch twice when localizer needle deflection is near 50% of full scale. If on this inbound leg you wish to rearm the glideslope, press the **NAV** switch only once.

Procedure Turn for Glideslope Approach

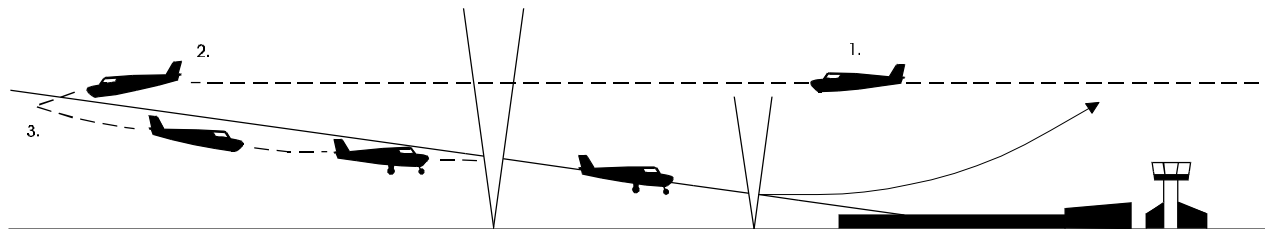

1. a. Tune navigation radio to ILS frequency.
b. Follow the procedure(s) for LOC Approach Intercept and Tracking in this manual.
2. a. If a procedure turn is required, enter the procedure turn above the published altitude.
b. Upon entering the inbound procedure turn sequence, press the **VS** mode switch.
c. Rotate the **VS SELECTOR** knob to establish the desired rate of descent to reach approach altitude at completion of the procedure turn.

d. Upon reaching approach altitude, press the **ALT** mode switch.
e. When the **NAV** mode switch is pressed, and if the aircraft is below the glide-slope, the **APR** and **GS** annunciations will illuminate, along with the **ALT** annunciation.
f. Upon capture of the glide-slope, the **ALT** annunciation will extinguish. (See text, ref. Glideslope Operation.)
3. a. If a circling, or straight-in approach to the ILS course is established, descend to approach altitude well in advance of reaching the outer marker.

b. Upon reaching approach altitude, press the **ALT** mode switch.
c. Upon capture of LOC course, **NAV**, **APR**, **ALT** and **GS** will illuminate if all conditions for glideslope operation are met (see text, ref. Glideslope Operation). This signifies automatic arming of the Glideslope function.
d. Upon Glideslope capture, the **ALT** annunciation will extinguish, signifying GS capture.

glideslope prior to reaching the outer marker, follow the procedure outlined in the text on Manual Arming of the Glideslope.

NOTE

If the final approach flown locates the aircraft *above* the

Glideslope Intercept and Track

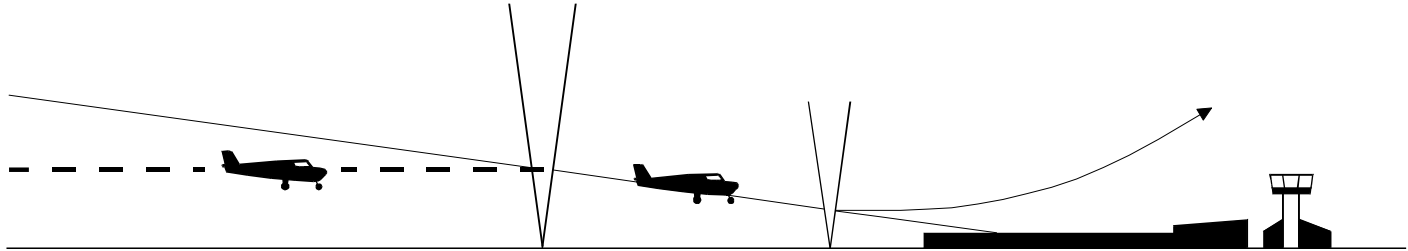

Flying the Glideslope

When making an ILS approach, be sure to follow the published procedure for the approach you have been cleared to make. (See text for Localizer Intercept and Tracking.)

Approach the glideslope intercept point with the aircraft stabilized in the altitude hold (ALT) mode. If the

aircraft requires approach flaps, lower the flaps to the proper position. (refer to FAA/AFM supplement for flap use limitations.)

At glideslope intercept, lower the landing gear (if applicable) and adjust power for the desired descent speed and published rate of descent. For best tracking results,

make power adjustments in small, smooth increments to maintain the desired rate of descent and airspeed.

At the missed approach point, or decision height, or the autopilot's minimum operating altitude, whichever is higher, disengage the auto-pilot to execute a manual landing, or a go around

maneuver. If a missed approach is declared, the autopilot can be re-engaged after a stabilized climb has been established.

NOTE

The pilot may elect to use **CWS** while maneuvering the aircraft for the missed approach.

Procedure Turn Back Course Localizer Approach (Standard D.G.)

Select the appropriate localizer frequency. Set the heading bug to the Front course **INBOUND** localizer heading and engage the **NAV** mode to track the localizer back course outbound.

When a localizer is channeled and **NAV** mode is selected, the System 55 will automatically execute high sensitivity gain for the approach and **NAV** and **APR** will be annunciated.



If the course needle is at full-scale deviation, the autopilot will establish a 45° intercept angle. As the aircraft approaches the localizer course, the autopilot senses the closure rate, and gradually, smoothly shallows the intercept angle. The point at which this turn begins is variable, depending on the aircraft position and closure rate to the course. However, the turn will always begin between 100% (full-scale) needle deflection and 20% of full-scale.

During the intercept sequence, the system operates in maximum gain and sensitivity to needle position and motion; 90% of standard rate turn. When the localizer course is intercepted, and the needle is centered, indicating course capture, initiation of the tracking gain program is automatic.

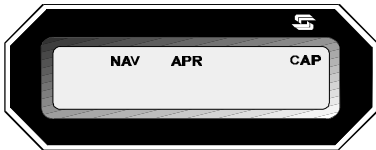

If the aircraft is equipped with the optional annunciator, the **NAV**, **APR** and **CAP** modes will be annunciated.

The high sensitivity level is maintained for about 15 seconds while wind correction angle is established. Turn rate maximum is then reduced to 45% standard rate.

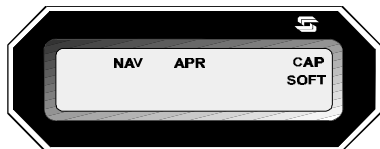

The optional remote annunciator will indicate *NAV*, *APR*, *CAP* and *SOFT*.

If the heading bug is within 5° of center and needle deflection is less than 10%, the System 55 computer will immediately establish this sensitivity level when **NAV** is selected.

Set the heading bug to the outbound procedure turn heading and select heading mode. At the appropriate time, in 90° increments, set the heading bug to the inbound procedure turn heading. Once established on the inbound procedure turn heading, follow the localizer back course intercept and tracking procedures for standard D.G.

Back Course Procedure Turn, Standard DG

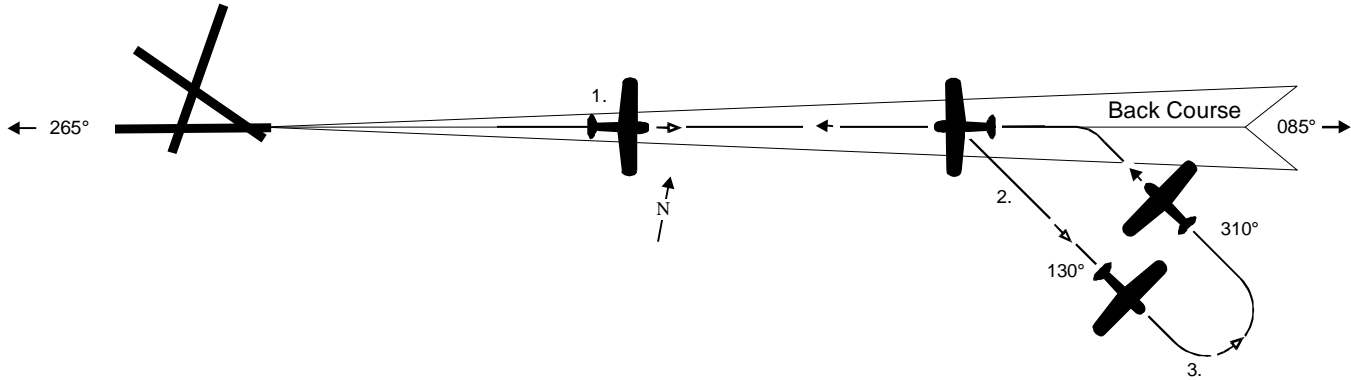

1. **a.** Tune navigation receiver to LOC frequency.
- b.** Set heading bug to published *inbound front course* heading.
- c.** Press **NAV** mode switch.

2. **a.** Set heading bug to out-bound procedure turn heading.
- b.** Press **HDG** mode switch.

3. **a.** In 90° increments, set heading bug to inbound procedure turn heading.

4. **a.** Set heading bug to published final approach course heading.
- b.** Press **REV** mode switch. Autopilot will complete intercept, capture and tracking of localizer back course.

Localizer Back Course Intercept and Tracking (Standard D.G.)

With the appropriate localizer frequency selected, set the heading bug to the INBOUND Back Course localizer heading and engage the **REV** mode to track the localizer back course inbound or front course outbound.

When a localizer is channeled and **REV** mode is selected, the System 55 will automatically execute high sensitivity gain for the approach and automatically activate the **APR** mode. **REV** and **APR** will be annunciated.

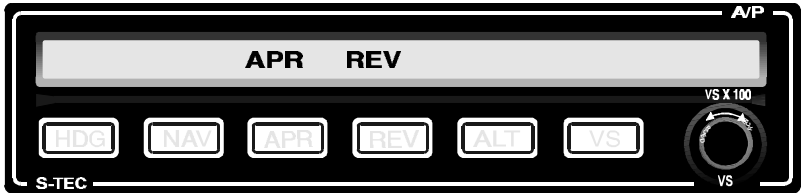

If the course needle is at full-scale deviation, the autopilot will establish a 45° intercept angle. As the aircraft approaches the localizer course, the autopilot senses the closure rate, and gradually, smoothly shallows the intercept angle. The point at which this turn begins is variable, depending on the aircraft position and closure rate to the course. However, the turn will always begin between 100% (full-scale) needle deflection and 20% of full-scale.

During the intercept sequence, the system operates in maximum gain and sensitivity to needle position and motion: 90% of standard rate turn. When the localizer course is intercepted, and the needle is centered, indicating course capture, initiation of the tracking gain program is automatic.



If the aircraft is equipped with the optional annunciator, the **REV**, **APR** and **CAP** modes will be annunciated.

The high sensitivity level is maintained for about 15 seconds while wind correction angle is established. Turn rate maximum is then reduced to 45% of standard rate.

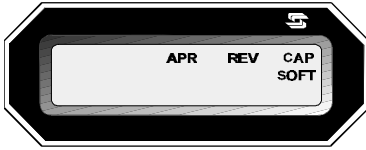

The optional remote annunciator will indicate *REV*, *APR*, *CAP* and *SOFT*.

If the heading bug is within 5° of center and needle deflection is less than 10%, the computer will immediately establish this sensitivity level when *NAV* is selected.

The system includes a course deviation monitor. If the aircraft strays off LOC centerline by 50% needle deflection, the *NAV* annunciator flashes a warning. It also flashes when the OBS NAV flag is displayed. When that occurs, the *FAIL* annunciation will illuminate.

PILOT SELECTABLE INTERCEPT ANGLE (S)

The pilot may select an angle of intercept less than the standard 45°. Simply place the heading bug on the D.G. on the desired heading to be used for the course intercept and push both *HDG* and *REV* switches simultaneously. *HDG*, *REV* and *APR* will be annunciated.



The selected heading will now be flown until the autopilot computes that an on course turn must be made to minimize overshoot at the point of intercept. At the time the on course turn begins, the **HDG** mode will extinguish and the heading bug must be moved to match the localizer back course inbound. This will allow the autopilot the full range of cross wind correction during **NAV, APR** track mode.

NOTE: INTERCEPT ANGLES GREATER THAN 45° USUALLY RESULT IN SOME COURSE OVERSHOOT, DEPENDING ON THE DISTANCE FROM THE STATION AND AIRCRAFT SPEED. THEREFORE, ANGLES GREATER THAN 45° ARE NOT RECOMMENDED.

Back Course Straight-In Approach, Standard DG

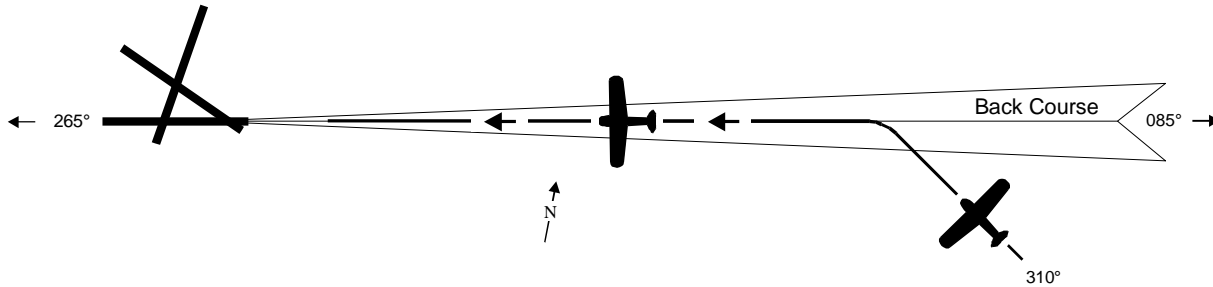

1. **a.** Tune navigation radio to LOC frequency.
- b.** Set heading bug to inbound final approach heading.

- c.** Press **REV** mode switch. Autopilot will intercept and track the back course to the airport.

Procedure Turn Localizer Back Course Approach (Optional H.S.I.)

Select the appropriate localizer frequency. Set the course selector to the INBOUND Localizer FRONT Course and engage the **NAV** mode to track the localizer back course outbound or front course inbound.

When a localizer is channeled and **NAV** mode is selected, the System 55 will automatically execute high sensitivity gain for the approach and **NAV** and **APR** will be annunciated.



If the course needle is at full-scale deviation, the autopilot will establish a 45° intercept angle. As the aircraft approaches the localizer course, the autopilot senses the closure rate, and gradually, smoothly shallows the intercept angle. The point at which this turn begins is variable, depending on the aircraft position and closure rate to the course. However, the turn will always begin between 100% (full-scale) needle deflection and 20% of full-scale.

During the intercept sequence, the system operates in maximum gain and sensitivity to needle position and motion: 90% of standard rate turn. When the localizer course is intercepted, and the needle is centered, indicating course capture, initiation of the tracking gain program is automatic.



If the aircraft is equipped with the optional annunciator, the **NAV**, **APR** and **CAP** modes will be annunciated.

The high sensitivity level is maintained for about 15 seconds while wind correction angle is established. Turn rate maximum is then reduced to 45% standard rate.

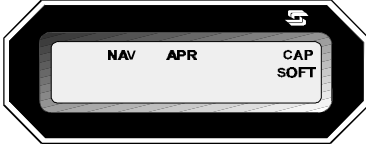

The optional remote annunciator will indicate *NAV*, *APR*, *CAP* and *SOFT*.

If the course selector is within 5° of center and needle deflection is less than 10%, the computer will immediately establish this sensitivity level when **REV** is selected.

Set the heading bug to the outbound procedure turn heading and select heading mode. At the appropriate time, in 90° increments, set the heading bug to the inbound procedure turn heading. Once established on the inbound procedure turn heading, follow the localizer back course intercept and tracking procedures for optional H.S.I.

Back Course Procedure Turn with Optional HSI

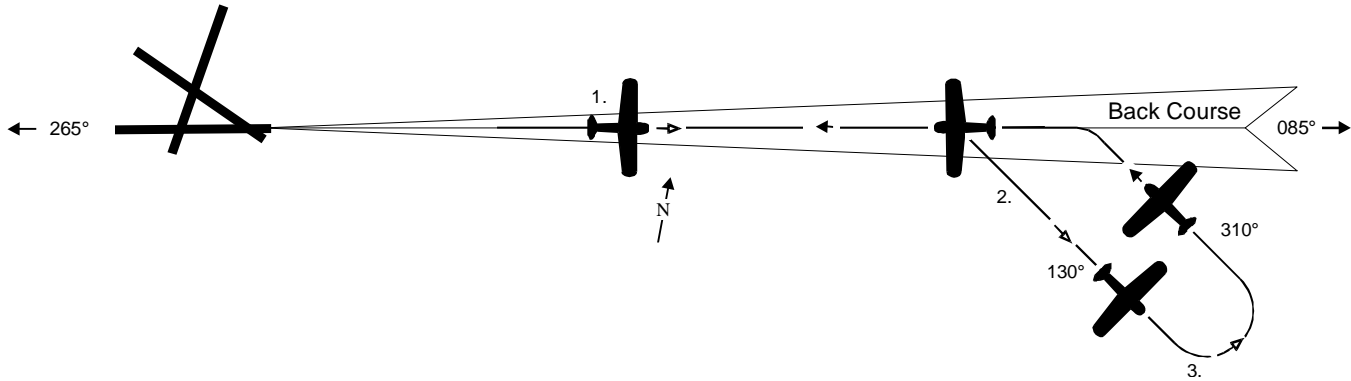

REverse mode is used to track the front course outbound or the back course inbound to the airport.

The HSI Course Pointer **MUST** be set to the front course inbound heading.

- 1. a.** Tune the navigation receiver to LOC frequency.
- b.** Set course pointer to published inbound LOC front course heading.
- c.** Press **NAV** mode switch. Autopilot will capture and track back course outbound.

- 2. a.** Set heading bug to published outbound procedure turn heading.
- b.** Press **HDG** mode switch.

- 3. a.** In 90° increments, set heading bug to inbound procedure turn heading.
- b.** Press **REV** mode switch. Autopilot will intercept, capture and track back course inbound to the airport.

Localizer Back Course Intercept and Tracking (Optional H.S.I.)

With the appropriate localizer frequency selected, set the course selector to the INBOUND Localizer FRONT Course and engage the **REV** mode to track the localizer back course inbound or front course outbound.

When a localizer is channeled and **REV** mode is selected, the System 55 will automatically execute high sensitivity gain for the approach and automatically activate the **APR** mode. **REV** and **APR** will be annunciated.

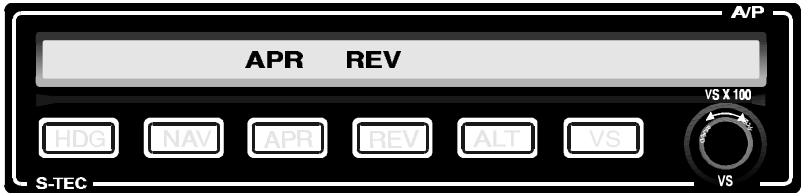

If the course needle is at full-scale deviation, the autopilot will establish a 45° intercept angle. As the aircraft approaches the localizer course, the autopilot senses the closure rate, and gradually, smoothly shallows the intercept angle. The point at which this turn begins is variable, depending on the aircraft position and closure rate to the course. However, the turn will always begin between 100% (full-scale) needle deflection and 20% of full-scale.

During the intercept sequence, the system operates in maximum gain and sensitivity to needle position and motion: 90% of standard rate turn. When the localizer course is intercepted, and the needle is centered, indicating course capture, initiation of the tracking gain program is automatic.



If the aircraft is equipped with the optional annunciator, the **REV**, **APR** and **CAP** modes will be annunciated.

The high sensitivity level is maintained for about 15 seconds while wind correction angle is established. Turn rate maximum is then reduced to 45% standard rate.

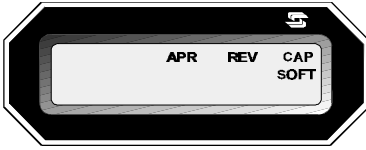

The optional remote annunciator will indicate *REV*, *APR*, *CAP* and *SOFT*.

If the course selector is within 5° of center and needle deflection is less than 10%, the computer will immediately establish this sensitivity level when **NAV** is selected.

Since the heading bug is not used for the final approach segment, the pilot may elect to move the heading bug to the published missed approach heading for reference and use in the heading mode, should a missed approach be necessary.

The system includes a course deviation monitor. If the aircraft strays off LOC centerline by 50% needle deflection, the *NAV* annunciator flashes a warning. It also flashes when the H.S.I. NAV flag is displayed. When that occurs, the *FAIL* annunciation will illuminate.

PILOT SELECTABLE INTERCEPT ANGLE (S)

The pilot may select an angle of intercept less than the standard 45°. Simply place the heading bug on the desired heading to be used for the course intercept and push both **HDG** and **REV** switches simultaneously. *HDG*, *REV* and *APR* will be annunciated.



The selected heading will now be flown until the autopilot computes that an on course turn must be made to minimize overshoot at the point of intercept. At the time the on course turn begins, the *HDG* mode will extinguish.



NOTE: INTERCEPT ANGLES GREATER THAN 45° USUALLY RESULT IN SOME COURSE OVERSHOOT, DEPENDING ON THE DISTANCE FROM THE STATION AND AIRCRAFT SPEED. THEREFORE, ANGLES GREATER THAN 45° ARE NOT RECOMMENDED.

Back Course Straight-In Approach, Optional HSI

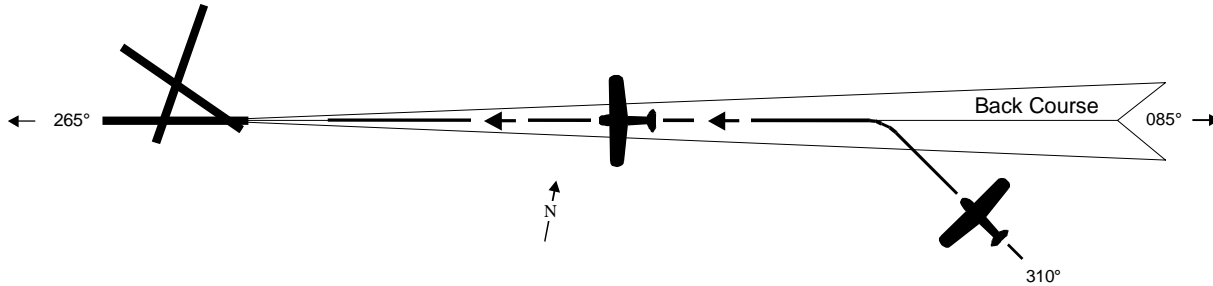

- 1. a.** Tune navigation radio to LOC frequency.
- b.** Set *Course Pointer* to published *inbound front course*.
- c.** Press **REV** mode switch.
- d.** Heading bug can be set to missed approach heading after course capture.

NOTE:

To establish a selected angle of intercept (dual mode intercept), on the back heading, set the course pointer to the published *inbound front course*

heading, and the heading bug to the desired heading to establish the selected angle intercept.

Press the **HDG** and **REV** mode switches simultaneously. Upon capture of the back course, the autopilot automatically cancels **HDG** mode and tracks the final approach course.

Single-Cue Flight Director Operation (Optional)



This system, which integrates both the roll axis and pitch axis, offers synchronized display of the flight profile. It is automatically activated when the autopilot is engaged. A Flight Director provides a visual indication of how accurately the pilot or autopilot is tracking the commands of the active mode of operation.



Activation is indicated by the **FD** annunciator on the remote annunciator.

A remote **Parallax Adjustment** is provided to change the height of the horizontal display to compensate for different seat heights and a remote switch allows flight director operation when the autopilot is not in use.

FD

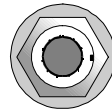

PLX ADJ

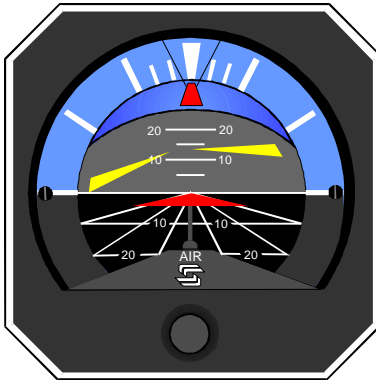

For proper flight technique, the system presentation requires the pilot to roll and pitch the aircraft toward the steering command bars until the delta-shaped reference is tucked into the steering command bars, indicating that commands have been satisfied. For example, if the display is up and left, the pilot would be required to establish a left turn, pitch-up attitude.



As bank angle and vertical speed approach the required amounts, bank angle and pitch-up attitude are shallowed. When the delta reference and the steering bars are matched the commands have been met. Thereafter, it is necessary to maneuver the aircraft to keep the display elements matched in order to accurately fly the programmed modes.

Accurate flight director operation requires alertness by the pilot and monitoring of the movement of the display. Keeping it matched is quite simple. However, control inputs must be timely for accurate flight director following of the desired command.

FD/AP

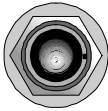

FD

For manually controlled flight by the flight director, place the **FD/AP** master switch in the "FD" position. This disables the autopilot servos, allowing the pilot to control the aircraft to the flight director commands.

OFF

FD/AP MASTER

FD/AP



FD

To engage the autopilot without interruption, simply place the **FD/AP** master switch in the "FD/AP" position.

OFF

FD/AP MASTER

NOTE: A PITCH MODE (ALT OR VS) AND A ROLL MODE (HDG, NAV, OR REV) MUST BE ACTIVATED BEFORE THE STEERING COMMAND BARS WILL COME INTO VIEW.

SYSTEM FAILURE AND CAUTION ANNUNCIATIONS

The System 55 contains a number of automatic failure and caution annunciations to advise the pilot of operational problems. They are as follows:

ANNUNCIATION	CONDITION	ACTION
Flashing RDY for 5 seconds with audible tone	Indicates Autopilot disconnect. All Annunciations except RDY are cleared.	N/A
Flashing RDY with Audible tone then Extinguished	Turn Coordinator Gyro Rotor Speed Low. Autopilot disconnects and can not be re-engaged.	Check Power to Turn Coordinator Conduct other system checks as necessary.
Flashing NAV, REV or APR	Indicates off Navigation course by 50% needle deviation or more.	Use HDG mode until Problem is identified. Cross-check raw NAV data, compass hdg, radio operation.
Flashing NAV, REV or APR , Steady FAIL	Indicates invalid Radio Navigational Signal.	Check NAV Radio for proper reception. Use HDG mode until problem is corrected.
Flashing VS	Indicates excessive Vertical Speed Error over selected VS (usually climb).	Reduce VS Command and/or adjust power as appropriate.
Flashing GS	Indicates off glideslope centerline by 50% needle deviation or more.	Check attitude and power. Add or reduce power as appropriate.

Flashing <i>GS</i> , steady <i>FAIL</i>	Indicates invalid glideslope-radio navigation signal.	Disconnect autopilot and initiate go- around or missed approach as appropriate. Inform ATC.
Flashing <i>GS</i> Plus <i>ALT</i>	Indicates Manual Glideslope disable.	Re-enable by pushing NAV mode switch.

NOTE: IF ANY OF THE ABOVE FAILURE ANNUNCIATIONS OCCUR AT LOW ALTITUDE OR DURING AN ACTUAL INSTRUMENT APPROACH, DISENGAGE THE AUTOPILOT, EXECUTE A GO-AROUND OR MISSED APPROACH AS APPROPRIATE. INFORM ATC OF THE PROBLEM. DO NOT ATTEMPT TO TROUBLESHOOT OR OTHERWISE IDENTIFY THE NATURE OF THE FAILURE UNTIL A SAFE ALTITUDE AND MANEUVERING AREA ARE REACHED OR SAFE LANDING IS EXECUTED.

Autopilot Disconnect

The autopilot can be disconnected by any of the following actions:

- A.** Turn the **Autopilot Master** switch **OFF**.
- B.** Press the **Autopilot Disconnect/Trim Interrupt** switch on the aircraft's control wheel.
- C.** Pull the aircraft's **AUTOPILOT Circuit Breaker**.
- D.** If the aircraft is equipped with optional automatic trim and the pitch axis of the autopilot is engaged, depress the **Trim** switch on the aircraft control wheel.

SYSTEM 55 SPECIFICATIONS

Programmer/Computer

Power required:	14/28 VDC
Weight:	3.0 lbs.
Dimensions:	6.25 X 1.50 X 10.60 in.
TSO, Autopilot:	FAA C9c
TSO, Flight Director:	FAA C52a

Note: Unit will operate with either 14 or 28 VDC input; however, internal circuit board assemblies must be set up for a specific voltage.

Turn Coordinator

Power required	14/28 VDC
Flag voltage detector operating limits:	9.0 VDC (approx.)
Flag RPM detector operating limits:	Nominal RPM less 20%
Current requirements:	0.3 Amp
Weight:	1.8 lbs.
Dimensions:	3.28 X 3.28 X 5.62 in.

Directional Gyro

Power required:	Vacuum or pressure, 4.5 to 5.2 in. Hg
Minimum air flow:	2.2 CFM
Air filtration:	3 micron, 95%
Autopilot pickoff:	AC, linear transformer, 5 KHz, 8 VAC (pp), (supplied by Autopilot)
Weight:	3.4 lbs.
Dimensions:	3.38 X 3.38 X 8.35 in.
Internal lights:	14/28 VDC

Roll Servo

Power required:	14/28 VDC
Current requirements:	Included in System current requirements
Weight:	2.9 lbs.
Dimensions:	3.75 X 3.75 X 7.25 in.

(cont.)

Specifications (cont.)

Pitch Servo/Trim Sensor

Power required: 14/28 VDC
Current requirements: Included in System current requirements
Weight: 2.9 lbs.
Dimensions: 3.75 X 3.75 X 7.25 in.

Altitude Pressure Transducer

Power required: 10 VDC
(supplied by Programmer/Computer)
Pressure range: 0 - 15 PSI absolute
Overpressure: 150% of operating maximum
Weight: 0.2 lbs.

System Current Requirements

(Approximate)	@ 14 VDC	@ 28 VDC
Average operating current:	1.0 Amp	0.5 Amp
Maximum current:	5.0 Amp	3.0 Amp

Options

Remote Annunciator

Power required: 0.2 Amp (max)
Weight: 0.75 lbs.
Dimensions: 1.60 X 3.42 X 3.80 in.

Flight Director Steering Horizon

(Requires installation of Remote Annunciator)

Power required: Vacuum or pressure, 4.5 to 5.2 in. Hg
Weight: 3.0 lbs.
Dimensions: 3.50 X 3.50 X 6.92 in.
Internal lights: 14/28 VDC

(cont.)

Specifications (cont.)

Automatic Elevator Trim

Power required:	14/28 VDC
Current requirements:	Included in System current requirements
Weight:	Included in System weight
Dimensions:	(internal, Programmer/Computer)

Trim Servo

Power required:	14/28 VDC
Current requirements:	0.5 Amp (avg.), 2.0 Amp (max)
Weight:	2.9 lbs.
Dimensions:	3.75 X 3.75 X 7.25 in.

Other available options not covered in this Handbook:

- ST-119 Altitude/Vertical Speed Preselector
- ST-180 Slaved Horizontal Situation Indicator System
- ST-360 Altitude Selector/Alerter
- Yaw Damper (approved for many single and twin engined aircraft)

S-TEC Corporation
One S-TEC Way • Municipal Airport
Mineral Wells, Texas 76067-9236 U.S.A.
Telephone 940/325-9406; FAX 940/325-3904
1-800/USA-STEC
s-tec.com

The information in this publication is subject to change without notice.

P/N 8779

03/99

Printed in U.S.A.